

100 Plus™

X-RAY FILM PROCESSOR 115 (VAC)

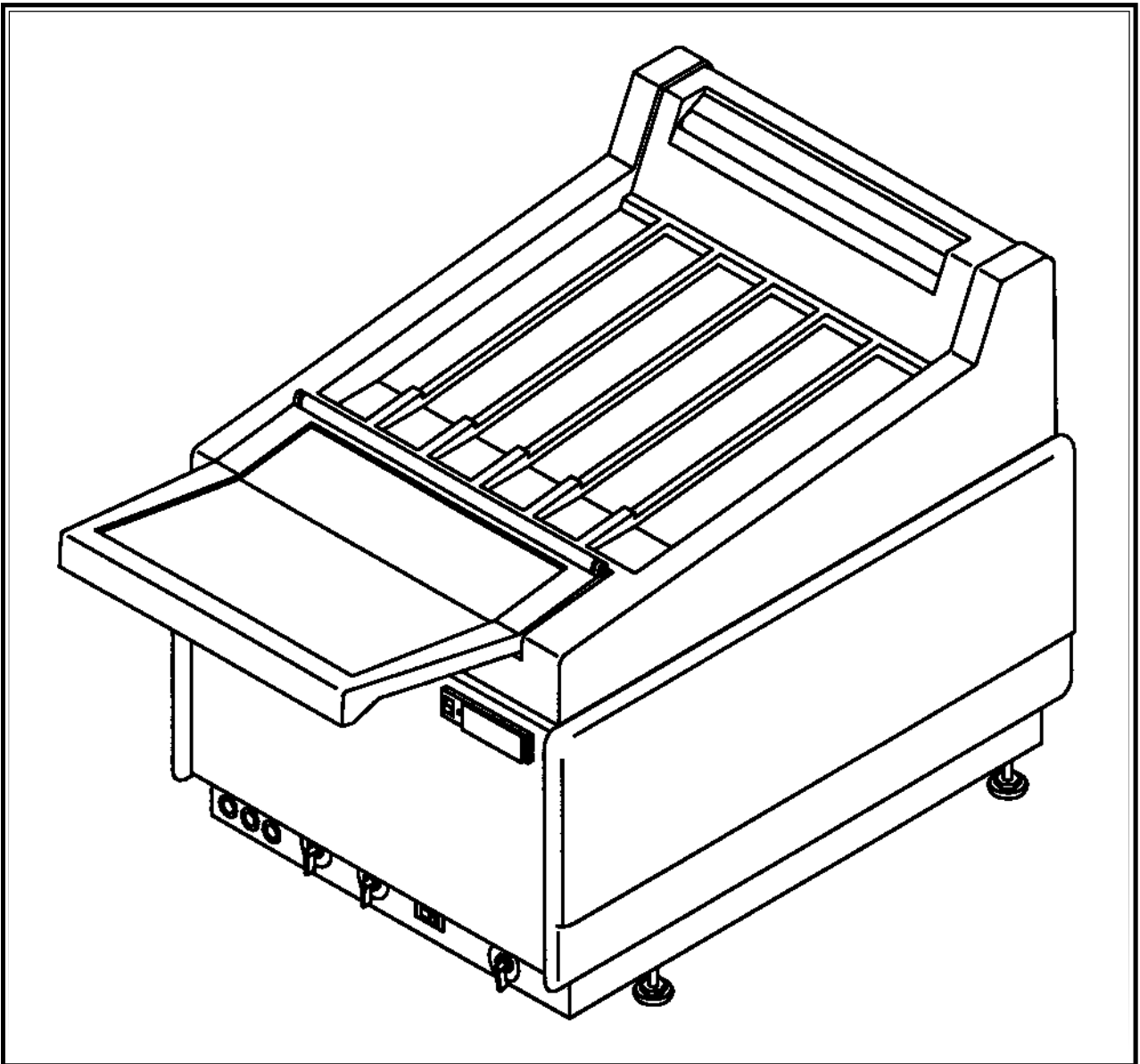

A6732  ISO 9001
EN 46001
Air Techniques Inc.
Hicksville, NY

All-Pro Imaging
DEDICATED TO QUALITY

TABLE OF CONTENTS

ABOUT THE 100 PLUS™	2
WARRANTY	3
SAFETY WARNINGS	3

PREINSTALLATION

KEY PARTS IDENTIFICATION (EXTERNAL)	4
KEY PARTS IDENTIFICATION (INTERNAL)	5
SPECIFICATIONS	6
SITE REQUIREMENTS	7
STANDPIPE INSTALLATION	8
RECOVERY CONTAINERS AND STANDPIPE INSTALLATION	9
TOOLS REQUIRED	10
UNPACK THE 100 PLUS	10
MOUNT PROCESSOR	10
TEST WITH WATER FOR SEAL INTEGRITY	11
INSTALL DRYER TRANSPORT	11
FILL WITH CHEMISTRY	12
INSTALL DEVELOPER, FIXER, WASH TRANSPORTS	12
SET DEVELOPER TEMPERATURE	13
SET DRYER POWER	13
CALIBRATE REPLENISHMENT PUMPS	14
SET "FLOOD" REPLENISHMENT	15
CHECK DRIVE BELT TENSION	16
FINAL ASSEMBLY	17

OPERATION

OPERATOR CONTROLS	18
STATUS LIGHTS	19
DAILY OPERATION	20

Table 1: Film Series Processing Time

SERVICE

MAINTENANCE	
Daily, Monthly, Quarterly	21
STATUS/ SERVICE DIAGNOSTIC LIGHTS	22-26

TROUBLE SHOOTING

Table of Contents	27
Equipment, Film, Electrical Problems	28-38
Table 2: Voltage and Resistance Values	39
Table 3: Thermistor Temperature/ Resistance Values	40

PARTS / ASSEMBLIES:

Table of Contents	41
Exterior, Interior, Transports (Listings and Illustrations)	42-57

ADDENDA

WIRING SCHEMATIC	58
PLUMBING SCHEMATIC	59

EXCELLENCE IN PROCESSOR PERFORMANCE

Your 100 PLUS X-ray Film Processor is designed and manufactured in the U.S.A by All-Pro Imaging. Every processor bearing the All-Pro name meets our high standards for manufacturing and performance excellence. From design through production you are assured of quality images for every patient, every time.

OVERVIEW

Diagnostic films are delivered quickly with a 26 second feed time and a dry-to-drop processing time of 120 seconds for a 17" long film. Minimum film length is 4 inches; maximum film width is 14 inches. Both single-sided and two-sided emulsion film can be processed. (See Table 2, Film Series Processing Time, p.20)

Attention to design detail enhances the performance of the 100 PLUS. Film is fed into the front of the 100 PLUS and conveniently returned on top of the cover. The 100 PLUS alerts the operator to feed in another film with a READY LIGHT and audible tone. The light-tight covered feed tray, a time saving feature, eliminates waiting until the last film is completely inside the 100 PLUS before the operator can leave the darkroom.

With its microprocessor, the 100 PLUS automatically monitors and controls developer temperature and dryer power as well as developer, fixer and wash water levels. The STATUS LIGHTS, located behind the name plate on the front panel, display the status of every controlled function.

To initiate processing, just insert a film into the film inlet. The 100 PLUS automatically switches from standby to processing and automatically returns to standby when the last film is delivered. If no films have been processed for 10 minutes, the anticrystallization cycle automatically activates and turns the transport rollers for 10 seconds to rewet them. This helps prevent artifacts from appearing on the processed film. The anticrystallization cycle may be continued overnight by putting the DAY/NIGHT SWITCH into the Night position.

Chemistry replenishment is automatic and proportional to film length. For low volume users, "flood" replenishment can be selected to extend chemistry life by additional replenishment during the anticrystallization cycle.

Installation is simplified with separate developer, fixer and water drain hoses that can be routed through either the front or rear of the 100 PLUS. Cold water is supplied through the water solenoid at the rear of the processor. No special electrical wiring is required since the 100 PLUS operates from a standard 115VAC 15A 50/60Hz or 230VAC 10A 50/60 Hz circuit.

The 100 PLUS is designed to make all components readily accessible for servicing. The microprocessor control board, with its Diagnostic Service Lights, is conveniently located on the inside of the swing-down front panel behind a protective enclosure. Mounted on the chassis and easy to reach are the drive motor and replenishment pumps, in the front, and the single motor, dual head recirculation pumps, which fully purge when the tanks are drained, on the side.

By following a regular maintenance and service schedule, the 100 PLUS will provide years of dependable, reliable service. Congratulations. You made the right choice!

WARRANTY

ALL-PRO IMAGING 1 YEAR LIMITED WARRANTY

Your 100 Plus™ Automatic Film Processor is warranted to be free from defects in material and workmanship from the date of installation for a period of 1 year.

Any item returned freight prepaid to our factory in Hicksville, New York, through an authorized dealer, will be repaired or replaced at our option at no charge provided that our inspection shall indicate it to have been defective. Dealer labor, shipping and handling costs are not covered by this warranty.

This warranty does not apply to damage due to shipping, misuse, careless handling or repairs by other than authorized service personnel. All-Pro Imaging is not liable for indirect or consequential damage or loss of any nature in connection with this equipment.

This warranty is in lieu of all other warranties expressed or implied. No representative or person is authorized to assume any other liability for us in connection with the sale of our equipment.

All-Pro Imaging
PO Box 870
Hicksville, NY 11802
516-433-7676

© Copyright ALL-PRO IMAGING
100 PLUS™ is a trademark of ALL-PRO™
ALL-PRO® is a registered trademark of ALL-PRO™

SAFETY WARNINGS

WARNING: To prevent fire or electrical shock, do not expose this appliance to rain or moisture.

ATTENTION USERS:



This symbol alerts the user that important Operating and Maintenance instructions have been included with the unit. Read carefully to avoid any problems.



This symbol warns the user that uninsulated voltage within the unit may be of sufficient magnitude to cause electric shock.



This symbol indicates type B equipment in accordance with IEC 601-1

Key Parts Identification [External]

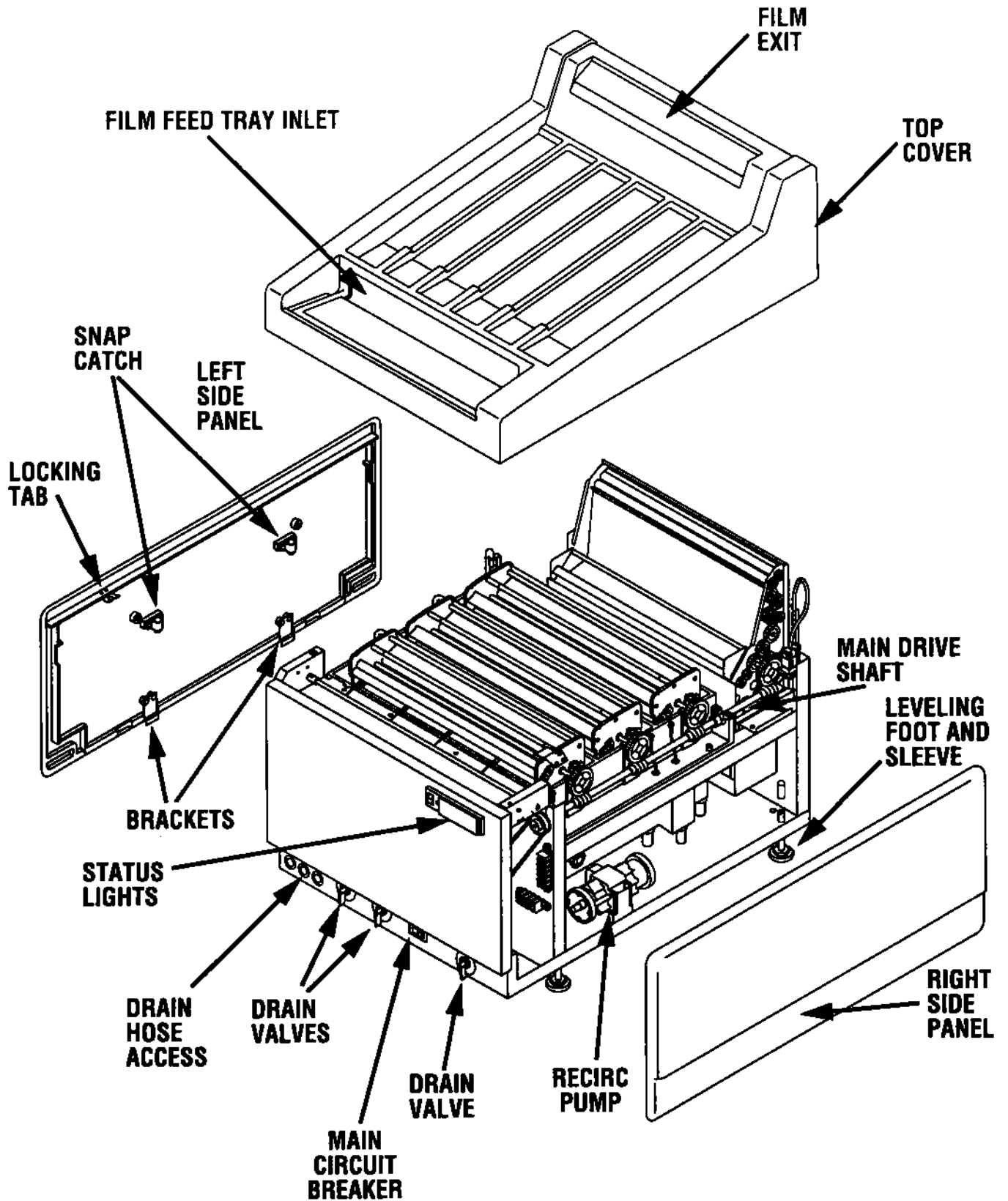

PREINSTALLATION

Key Parts Identification [Internal]

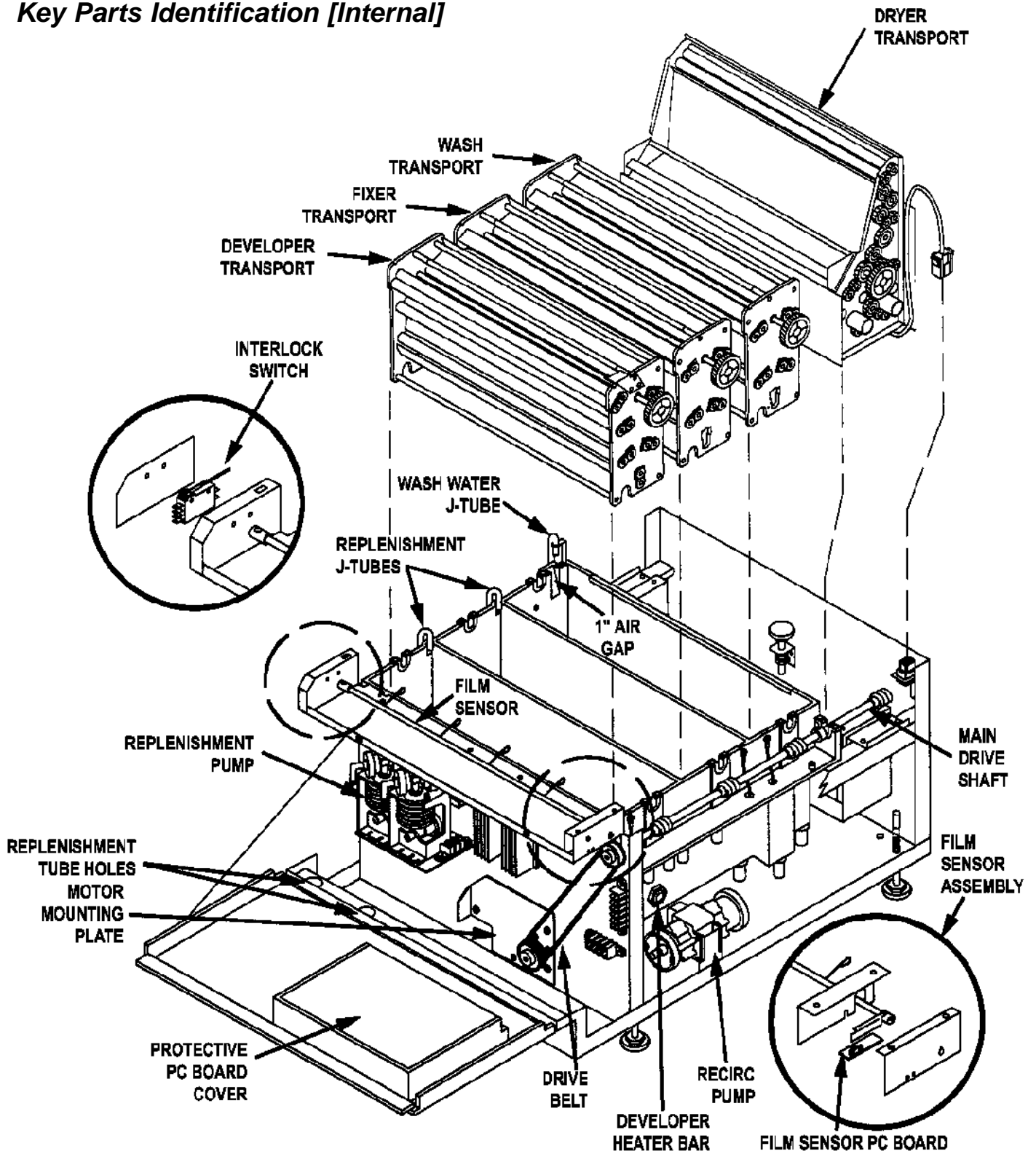

SPECIFICATIONS

FILM CAPACITY	138 films/hr..continuous feed. 17"/43cm in length.			
PROCESSING TIME				
<i>Film Length</i>	17"/43cm	14"/35cm	12"/ 30cm	10"/24cm
<i>Processing (sec.)</i>	94	94	94	94
<i>Feed Time (sec.)</i>	26	22	19	16
<i>Dry to Drop (sec.)</i>	120	116	113	110
FILM SIZES	4" sq (10cm x 10cm) up to 14" (35cm) wide by any standard length.			
FILM	Single-sided and two-sided emulsion film can be processed.			
REPLENISHMENT RATES	Developer and Fixer stroke volumes are individually adjustable by Service Technician. Replenishment is factory set to deliver 100cc for a 17" long film. Flood replenishment is selectable by Service Technician.			
REPLENISHMENT TANKS	Two color-coded containers. 6.8 gal. (25.8 liter) ea., 13-1/2" (34.3cm) diameter by 17-1/2 " (44.5cm) high.			
TANK CAPACITIES	2.0 gal (7.5 liter) ea. developer, fixer, water.			
DIMENSIONS	<i>Depth:</i> 27"(68.6cm) w/o covered feed tray 36" (91.4cm) w/covered feed tray <i>Width:</i> 22"(56cm) <i>Height:</i> 21 "(53.3cm) <i>Shipping Dimensions:</i> 2 cartons. each 24-1/2" x 30-1/2 x 28-1/2" (62cm x 77cm x 72cm)			
ELECTRICAL	115V 12A 50/60 Hz or 230V 6A 50/60 Hz			
WEIGHTS	Installed: 200 lbs (91) kg with fluids Total Shipping: 220 lbs (100kg)			

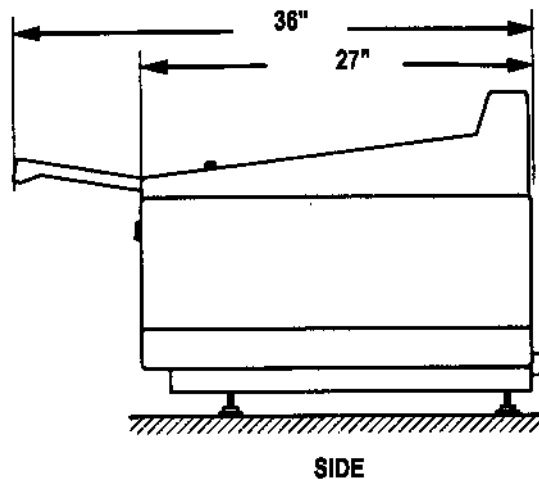
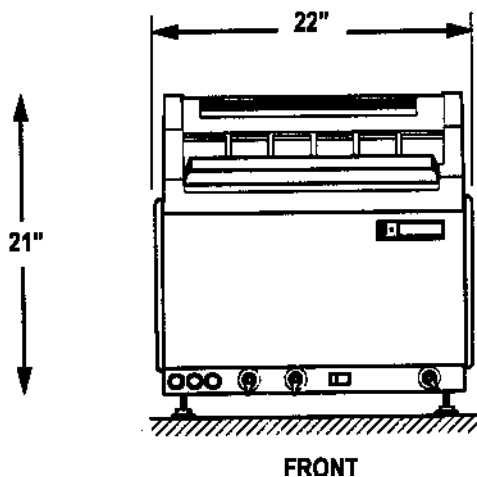

PREINSTALLATION

SITE REQUIREMENTS

- CLEARANCES**
- **SIDES:** 24" (61cm) recommended
 - **REAR:** 3" (8cm) recommended
 - **FRONT:** (Incl. film feed tray): 30"(76cm) recommended
 - **TOP COVER:** 18" (46cm) recommended
- COUNTER HEIGHT** 24" (61cm) - 32" (82cm) recommended
- WEIGHT** 200 lbs (91 kg) with fluids
- ELECTRICAL**
- 115V /15 A 50/60 Hz or 230V /10 A 50/60 Hz grounded outlet
Plug may need to be changed to meet local requirements
 - Processor equipped with a 6' (1.8m) long power cord
- WASH WATER**
- **Temperature:** 50° to 90° F (10° - 32° C)
 - **Pressure:** 40 to 100 psi (3 - 7 bar)
 - **Flow rate:** .5 gal/min (1.9 liter/min)
 - **Valve:** Dedicated on/off hose cock with 3/4" male garden hose fitting.
 - Water filtration may be required depending on area water conditions
 - If the water supply temperature exceeds 90° F (30°C), a water chiller may be required
- VACUUM BREAKER** Built-in 1" (2.5cm) air break prevents back syphoning.
- DRAIN**
- **CAPACITY:** 3 gal/min (11.4 liter/min)
 - **MATERIAL:** Must be corrosion-resistant material i.e. PVC, cast iron. Do not use copper, brass or aluminum.
 - **LOCATION:** 4" (10cm) minimum distance below bottom of processor
 - **CONNECTION:** Floor drain or open standpipe
 - Equipped with three color-coded drain hoses 8' (2.4m) long, 3/4" (1.9cm) ID, which must slope smoothly down from processor to drain without any "kinks", "U's" or upward bends. Route drain hoses through front or rear of processor
- VENTILATION**
- **Ambient Room Temp:** 59° - 86° F (15° - 30°C)
Relative Humidity: 15% to 76%
 - **Heat loads:** Standby: 250 BTU/hr (75 W)
Moderate use: 1700 BTU/hr (500 W)
 - Recommended ventilation rate: 10 air changes/hr
- SAFELIGHT** Follow film manufacturer's recommendations for type and size of safelight. Position safelight so that film feed tray area is illuminated and is not shadowed by the operator.

Standpipe Installation

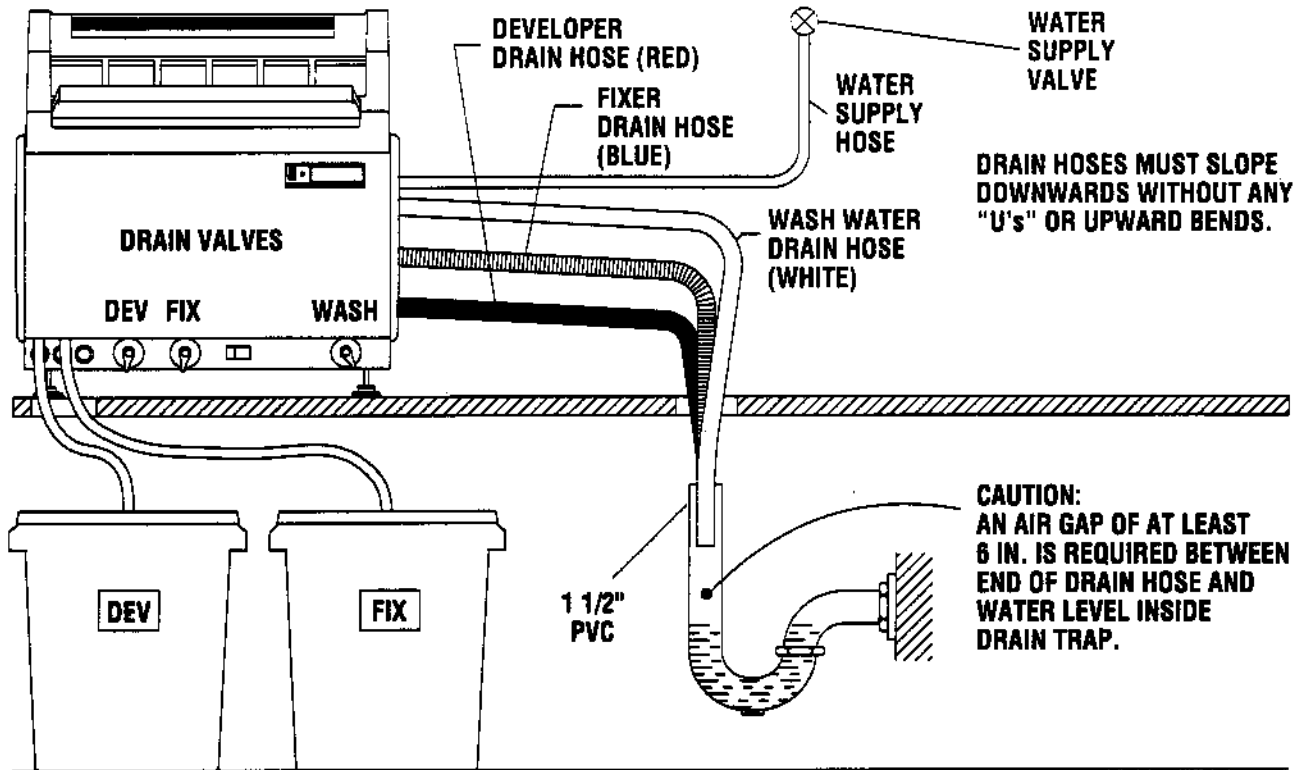

FOR STANDPIPE DRAIN INSTALLATIONS OBSERVE THE FOLLOWING

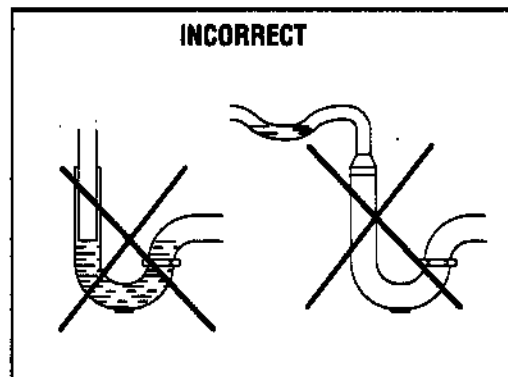
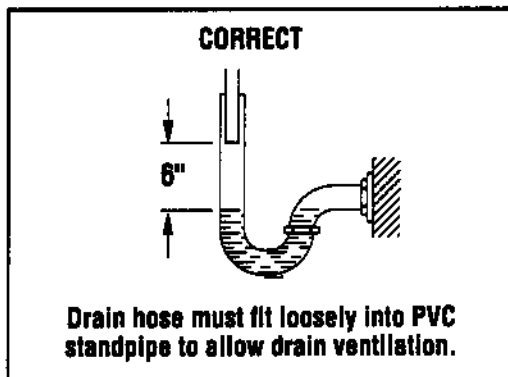

PREINSTALLATION

Recovery Containers and Standpipe Installation

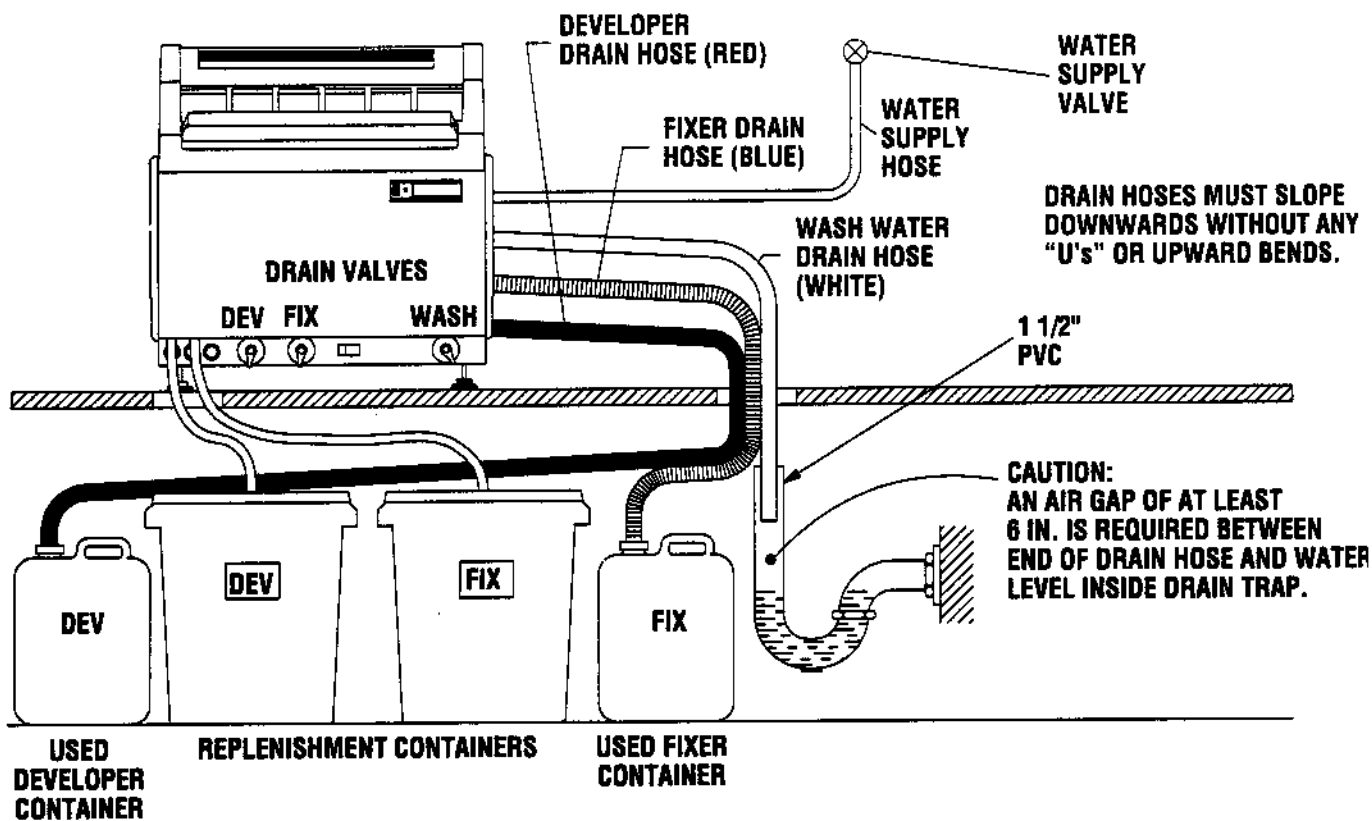

FOR STANDPIPE DRAIN INSTALLATIONS OBSERVE THE FOLLOWING

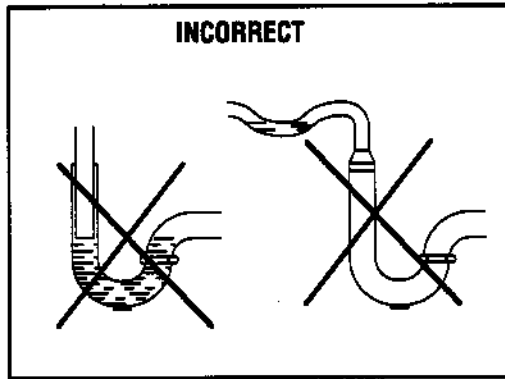
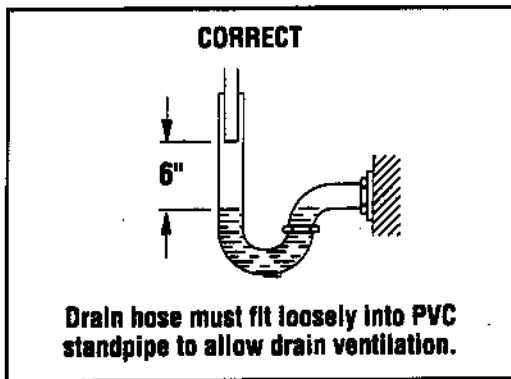

TOOLS REQUIRED

Screwdriver. flat blade. 3/16" tip
Screwdriver. Phillips head. #1
5/64" Allen wrench
3/4" Open ended wrench
Bubble level
Pliers
Knife or snips for cutting packing material
Calibrated beaker

PACKING CARTONS

The processor is packed in cartons as follows:

Carton marked CHASSIS contains:

- 100 PLUS Chassis Assembly
- Side Panels
- Top Cover
- Wall Chart
- Covered Feed Tray

Carton marked ACCESSORIES contains:

- Developer, Fixer, Wash and Dryer Transports
- Leveling Feet and Sleeves (4 each)
- Water Inlet Hose
- Replenishment Tanks, color-coded (2)
- Manual
- Warranty Card

UNPACK THE 100 PLUS

1. Cut the packing straps and remove the top of the CHASSIS carton.
2. Remove the processor cover.
3. Loosen the screws (2) that fasten the side panels to the chassis. Remove left and right side panels by pulling the top of each panel away from the chassis.
4. Cut and remove the plastic tie wrap from the main drive shaft.
5. Open the ACCESSORIES carton and remove the contents.

MOUNT PROCESSOR *[on user provided surface]*

Before making plumbing (and electrical) connections, be sure that the surface is flat, rigid and capable of supporting 200 lbs. An unstable surface may cause splashing and chemical contamination.

1. Lift the chassis by grasping it under the horizontal steel rails that support the tank flanges and place on a level surface.
2. Screw the leveling feet into the threaded inserts on the underside of the chassis. **Push hoses out of the way of the leveling foot's shaft as it is comes through the threaded insert.** Slip a sleeve over each shaft.
3. Open the front hinged panel by removing the two acorn nuts at the top of the panel. Remove the replenishment tubes and route the developer tube (red wand) through the left hole and the fixer tube (blue wand) through the right hole. The holes are on the left side of the chassis, in front of the replenishment pumps. If mounting on the optional stand, first attach the chassis to the stand before routing the hoses. Close the front hinged panel.
4. Route the drain hoses out the rear or front of the processor and into a floor drain or standpipe. (See p.6 & 7) The developer and fixer hoses can be routed into recovery containers. Make sure that the hoses slope smoothly down without any "kinks", "U's" or upward bends and cut off excess hose. If necessary, drill holes in the counter top to route hoses.

INSTALLATION

5. Level the processor front to back and side to side by adjusting the leveling feet. Check with bubble level.
6. Screw the elbow end of the garden hose onto the solenoid valve located on the back of the processor and connect the straight end to the water supply valve.

If installing the processor on the 100 PLUS stand, see Processor Stand Assembly in ADDENDA

TEST WITH WATER FOR SEAL INTEGRITY

All-fittings are factory tested. Follow this procedure to make sure no connections have loosened:

1. Fill the tanks with water.
2. Drain the tanks one at time by opening the drain valves located at the front bottom of the processor. (See Figure 1) As each tank drains, check all seals and connections. Close the valves after completely draining each tank.
3. Put on the left and right side panels (not interchangeable). Snap into place and fasten closed with screws.
4. Position the processor and recheck to make sure the processor is level.

Note: The wash water drain valve in the closed position allows a slow flow of water from the wash tank. The wash tank drains completely overnight to retard the growth of algae.

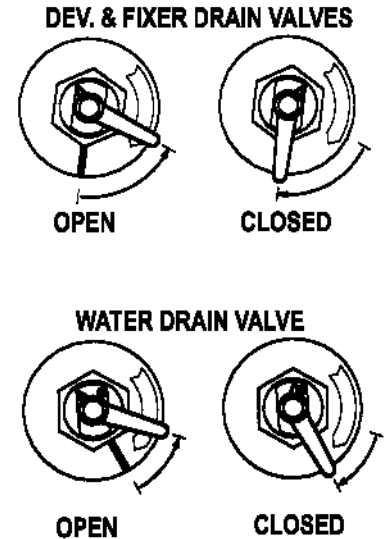

Figure 1

INSTALL DRYER TRANSPORT

1. Examine the dryer transport. Be sure that all snap rings, gears, tensioning bands and dryer air tubes are in place. Turn the main drive gear to check for free movement.

Caution: Before installing the transport: check the chassis assembly to be sure that the tie wrap has been removed from the main drive shaft. Also check that the front-most saddle bearing has been lubricated with white lithium grease or equivalent.

2. Install the dryer transport by lowering it into the opening behind the wash tank. Place securely onto the bracket in front of the transport (the back of the wash tank wall) and onto the support behind the transport (on the chassis). (See Figure 2) When installed, the main drive gear is engaged with the rearmost worm on the drive shaft. Be careful not to dislodge the dryer air tubes from the dryer side panels.
3. Plug the electrical connector from the dryer transport into the

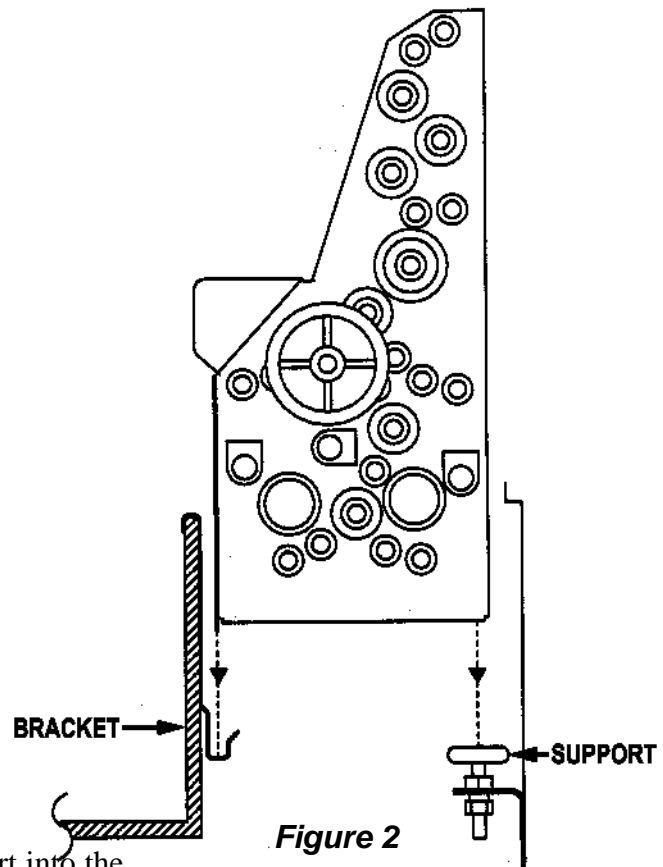

Figure 2

receptacle mounted on the upper right rear chassis of the 100 PLUS. (See Figure 3)

FILL WITH CHEMISTRY

Caution: Only use working strength Developer and Fixer for automatic processing. Make sure drain valves are closed.

1. Fill the fixer tank with fixer to 1" below the top of the tank (approximately 1.7 gal). Always fill the fixer tank first to reduce the chance of contamination. If fixer accidentally splashes into the developer tank, clean up before continuing.
2. Fill the developer tank with developer to 1" below the top of the tank (approximately 1.7 gal).
3. Fill the replenishment containers with developer and fixer. Place the floating cover inside the developer container. Place the covers on the containers and install the color-coded replenishment wands in each container through the hole in the top. Be sure that the wand goes through the slot in the floating cover in the developer.
4. Put the replenishment containers in place. Push the replenishment wands to the bottom of the containers. Make sure there are no kinks in the tubing.

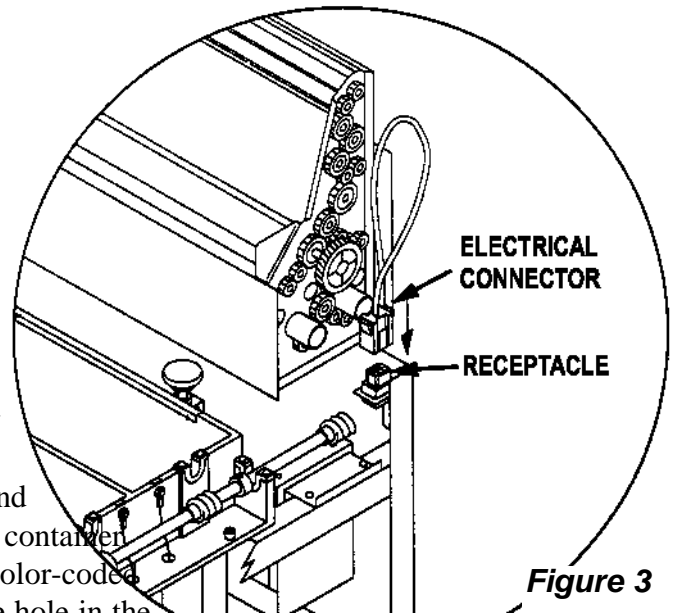

Figure 3

INSTALL DEVELOPER, FIXER, WASH TRANSPORTS

1. Check the developer, fixer and wash transports. Be sure that all snap rings, gears and tensioning bands are in place. Also check each transport for squareness. If necessary, adjust by placing the transport on a flat surface and loosen the screws on the cross ties. When the transport is square, retighten the screws. Turn each main drive gear to check for free movement.

NOTE: Transports are color-coded: developer transport has a red sleeve; fixer transport a blue sleeve; wash transport has no sleeve.

2. Slowly lower each transport into its tank. Avoid splashing. Install the developer transport in the front tank, the fixer transport in the middle tank and the wash transport in the rear tank. A thrust bearing on the left side of the rack drive shaft positions the transport from left to right in the tank. When installed, the main drive gear on each transport engages the main drive shaft worm.

INSTALLATION

WARNING!

Procedures in this section must be performed only by qualified service technicians. Safety interlocks will be bypassed and hazardous voltages will be present.

To perform many of the procedures detailed below, it is necessary to “defeat” the interlock switch. This is accomplished by inserting the blade of a screwdriver into the interlock switch opening. Point the blade toward the rear of the processor when inserting.

SET DEVELOPER TEMPERATURE

The developer temperature is factory set at 92.5°F (33.6°C). If it is necessary to change this setting to be in accordance with film manufacturer's temperature requirements, do the following:

1. Open the front hinged panel by removing the two acorn nuts at the top of the panel.
2. Open the protective cover by loosening the screws in the corners. Reset the potentiometer. Verify actual temperatures by following the procedure below.
3. Plug in the power cord, open the water supply valve, turn on the main circuit breaker, and put the Day/Night Switch into the Day position. Wait 15 - 20 minutes. The READY LIGHT will illuminate and an audible tone sound. Wait 5 minutes.
4. Press the film sensor to activate the process cycle. Use a thermometer accurate to within $\pm 1/4^\circ\text{F}$. Check the developer temperature by placing the thermometer **in the middle of the developer transport** and holding until the reading on the thermometer stabilizes. .
5. If the actual temperature is not the desired temperature, adjust the potentiometer accordingly and check the temperature again. Close the protective cover and tighten the screws.

NOTE: The developer tank must be full and STATUS LIGHT #4 (DEV LEVEL) must be “on”. If this condition is not met, the heater will not operate.

SET DRYER POWER

The dryer potentiometer is factory set at position 3. (See Figure 5, p. 15) If it is necessary to change the setting, do the following:

1. Open the protective cover by loosening the screws in the corners.
2. Set the potentiometer down to lower the power, set the potentiometer up to increase the power. Always set to lowest setting that delivers consistently dry film. Close the protective cover and tighten the screws.

CALIBRATE REPLENISHMENT PUMPS

The replenishment pumps on the 100 PLUS are set to pump 100cc of chemistry in 26 seconds. Check film manufacturer's guidelines for recommended replenishment rates. To check, and, if necessary, adjust these rates, follow the procedure detailed below:

1. Prime the replenishment pumps by pressing the film sensor. Hold down until the flow from the replenishment "J" tubes (on the left side of the tanks) is steady, indicating that all lines and pumps are properly filled. The replenishment pumps will operate for a maximum of 4 minutes as long as the film sensor is depressed. If the film sensor is depressed for more than 4 minutes, the replenishment pumps lock out. (See p. 18)
2. Check developer replenishment rate:
 - Raise and turn the developer "J" tube out of its socket and position it over a graduated beaker.
 - Hold down the film sensor for 26 seconds and collect the pumped chemistry. Note the amount collected.
3. To change the developer replenishment rate: (See Figure 4)
 - Expose the phillips head screw on the flywheel by rotating the pump flywheel clockwise with the tip of a screwdriver or by repeatedly depressing the film sensor.
 - Slightly loosen the screw and rotate the outermost plate of the flywheel to set the desired stroke volume.
 - To deliver less chemistry, rotate the flywheel counterclockwise. To deliver more chemistry rotate the flywheel clockwise. Tighten the screw to lock in the replenishment rate.
 - Hold down the film sensor for 26 seconds and collect the pumped chemistry. Note the amount collected.
 - If correct, replace the "J" tube in its socket.
 - If not correct, repeat the above procedure.
4. Perform steps 2 and 3 for the fixer replenishment pump.

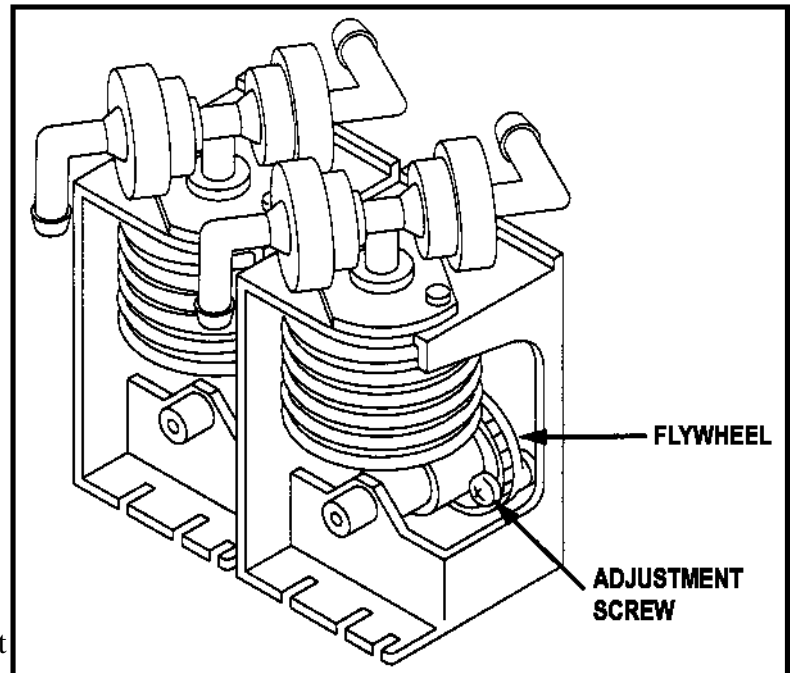

Figure 4

INSTALLATION

SET "FLOOD" REPLENISHMENT

For most users, replenishment on a per film basis is sufficient. However, if the installation is for low volume film users, it may be advisable to have the replenishment pumps operate during the anticrystallization cycle (every 10 minutes). Flood replenishment will not occur during the Night Mode. This "flood" replenishment will provide additional chemistry to counteract oxidation and extend the life of the chemistry.

1. To activate "flood" replenishment use the jumper plug provided in a plastic bag mounted on the inside of the front panel.
2. Open the protective cover and insert the jumper plug into the R12 position on the control board. (See Figure 5)
3. Recalibrate the replenishment pumps (See Calibrate Replenishment Pumps, p. 14) to deliver 50cc of chemistry in 26 seconds of open shutter time. (Set pump at 50% minimum setting)

Note: Temperature settings and replenishment flow rates are now calibrated. Remove the screwdriver from the interlock switch.

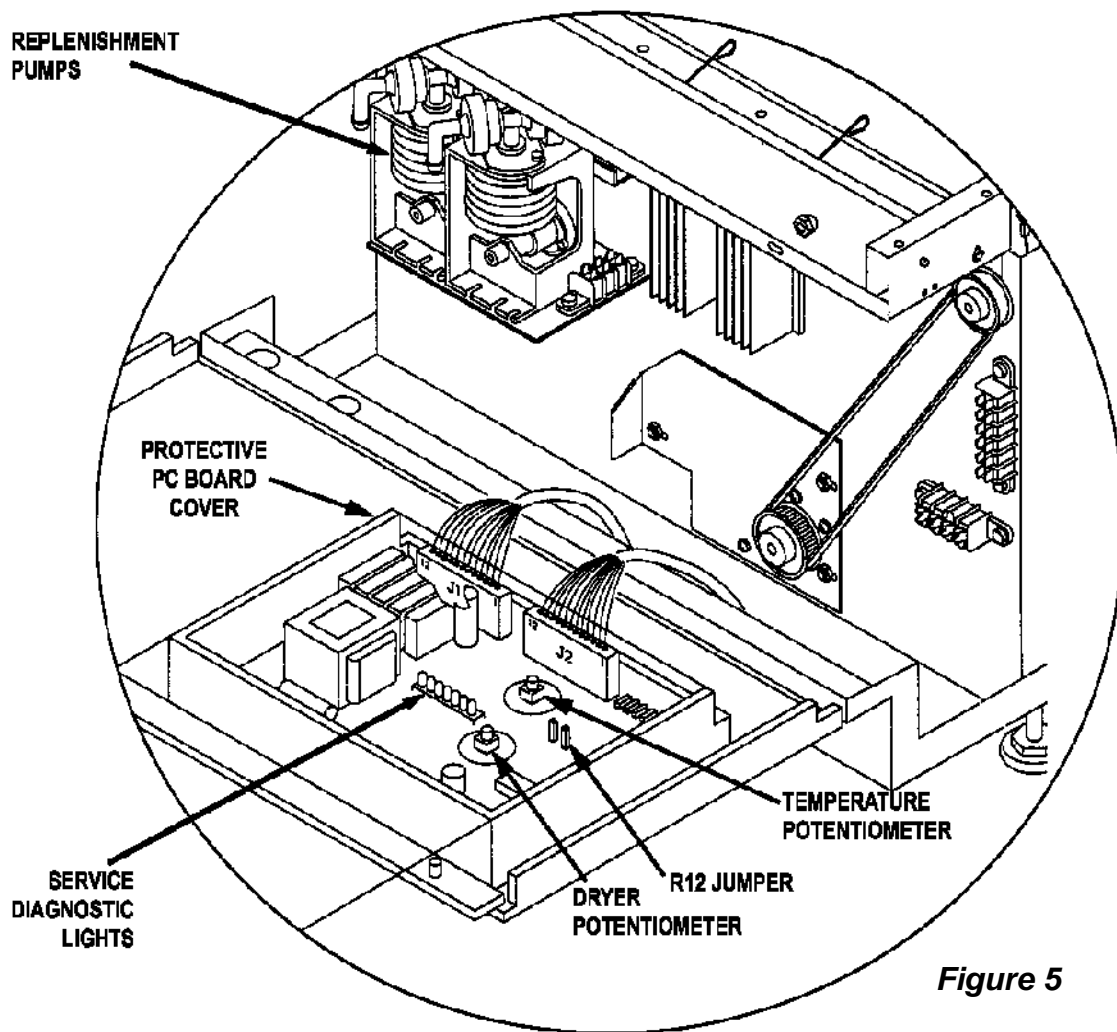

Figure 5

CHECK DRIVE BELT TENSION

1. Using light finger pressure (approximately 1/2 lb. of force). Press one side of the drive belt at midspan. It should deflect approximately 3/16". (See Figure 6)
2. If the drive belt deflects more or less than the 3/16", then the tension needs to be adjusted. First loosen the nuts on the motor mounting plate. Then shift the motor left to tighten the belt, right to loosen the belt.
3. Retighten the nuts when the desired tension has been reached.

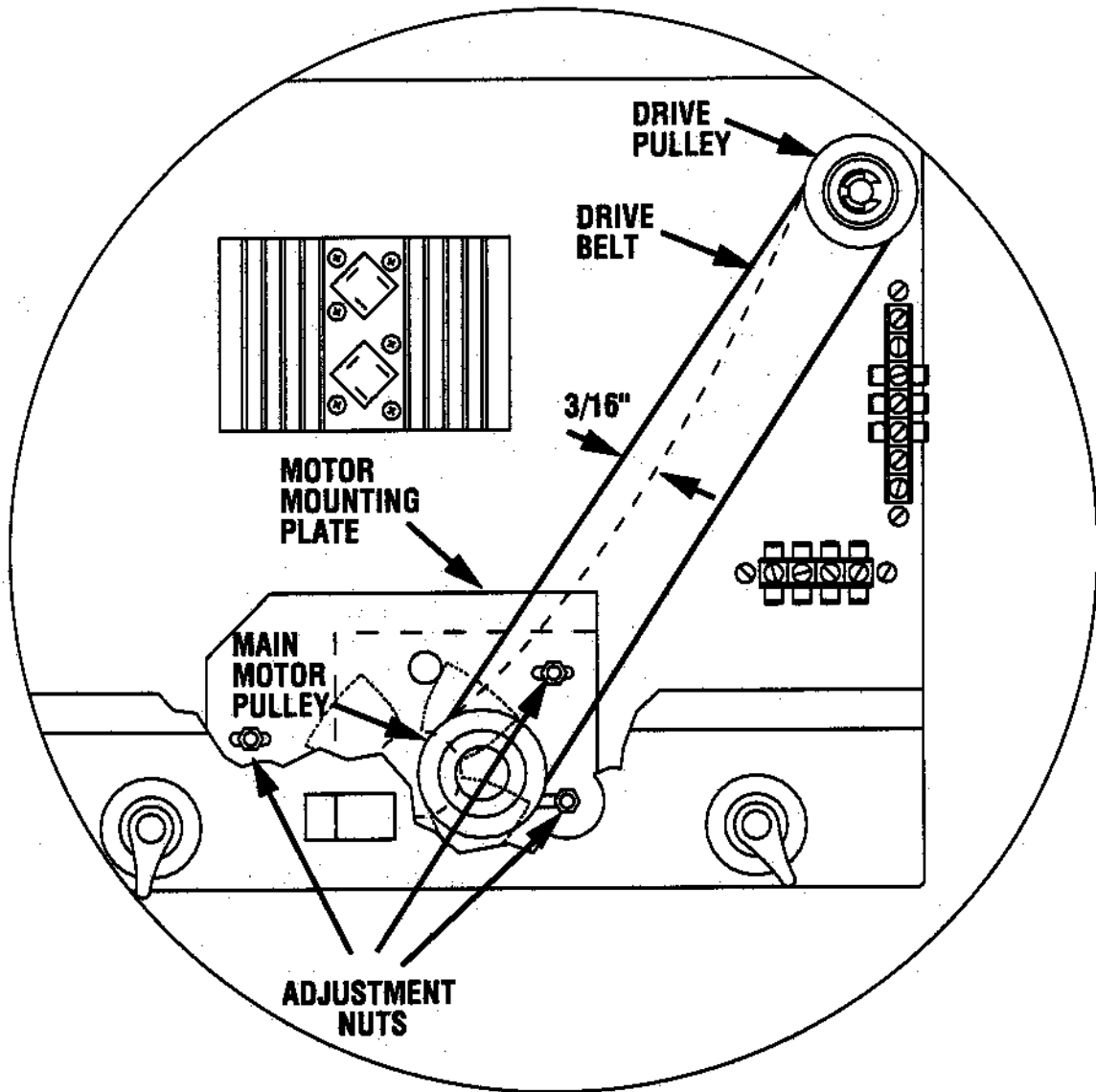

Figure 6

OPERATION

FINAL ASSEMBLY

1. First close the hinged front panel and fasten in place with the two acorn nuts provided. Put the top cover on.
2. Install the film feed tray (See Figure 7):
 - Hold the closed front end of the tray with both hands and tilt up slightly. Point the mounting brackets toward the film inlet.
 - Push the tray into the film feed tray inlet opening until the tray's mounting brackets hook onto the developer transport cross tie bar. Push down slightly while lowering the tray in place.
 - The cover of the feed tray must be flush with the top of the processor cover for proper installation.

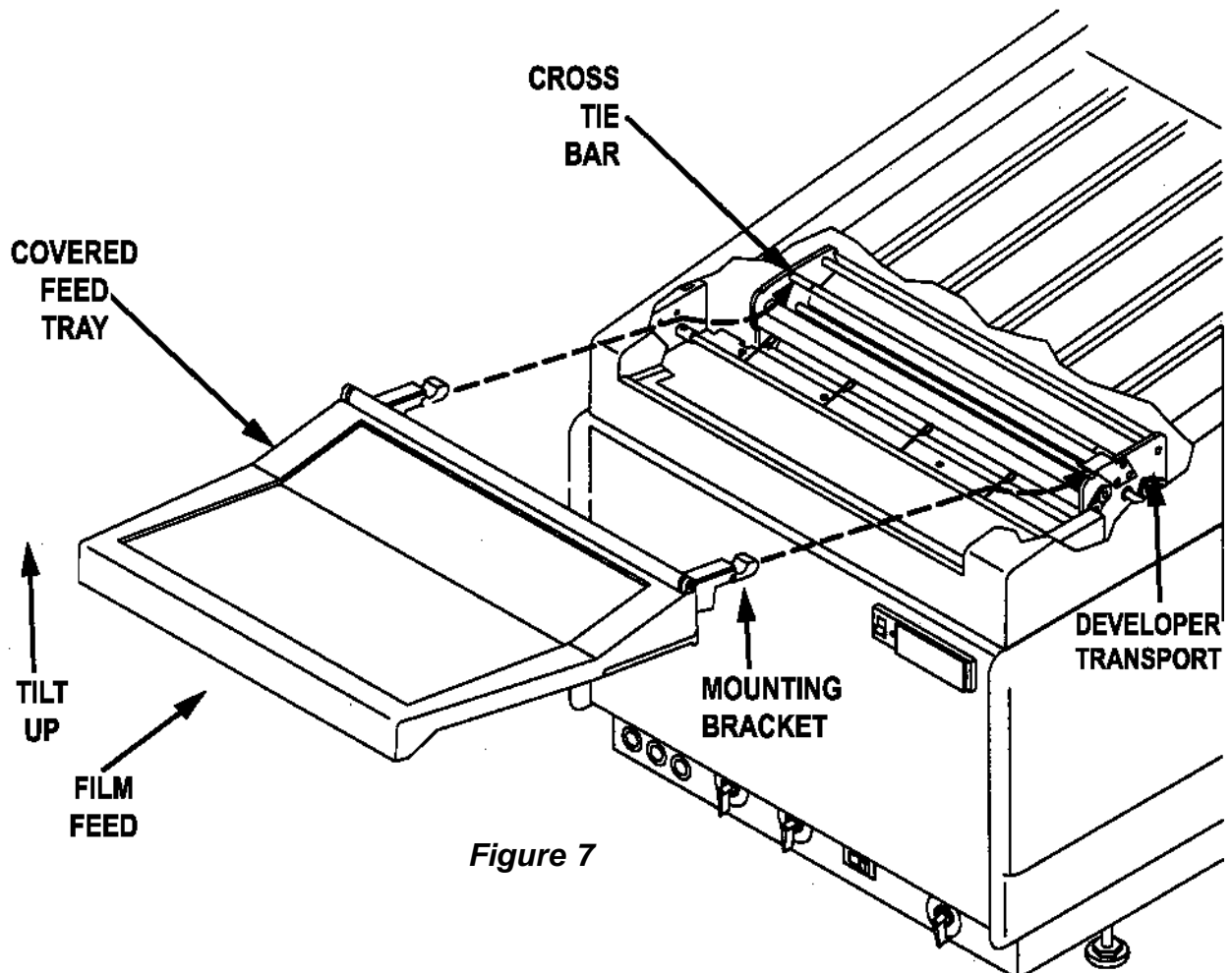

Figure 7

3. Run test films. If the films are excessively hot or not completely dry, set the potentiometer down to lower the power, set the potentiometer up to increase the power. Always set to the lowest setting that delivers consistently dry films. (See p. 13)
4. Mount the wall chart where it is visible to the operator.
5. Instruct the operator in the proper operation and maintenance of the processor.

OPERATOR CONTROLS

Main Circuit Breaker

Located at the bottom front of the processor, it is normally left on during the day. It is also left on at night to run the anticrystallization cycle in the Night Mode.

Day/Night Switch

Located to the left of the READY LIGHT. For normal processor operation, put into the Day position. The developer and dryer will heat and the wash tank will fill. The processor will remain in stand-by with the READY LIGHT illuminated when it is ready for use.

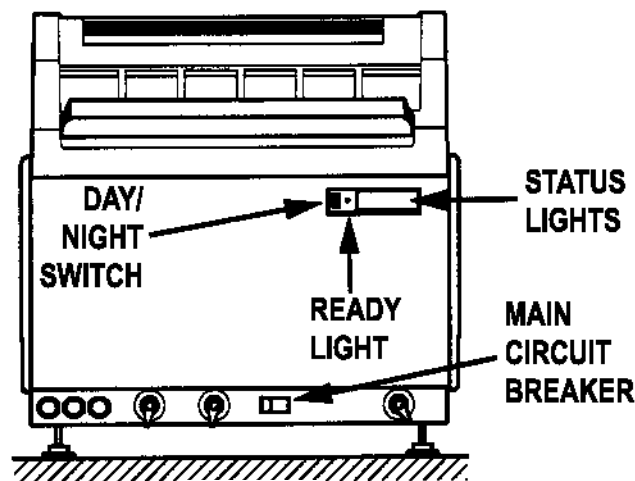

Figure 8

To continue the anticrystallization cycle overnight, put the Day/Night Switch in the Night position and leave the main circuit breaker on. The READY LIGHT flashes slowly. The developer and dryer will cool and the wash tank will slowly drain via the water valve weep hole. Flood replenishment does not occur.

Ready Light

- READY LIGHT (stand-by condition) illuminates when developer temperature and fluid levels are correct and if the film sensor is closed. The 100 PLUS is ready to process a film. If the READY LIGHT does not illuminate, check the STATUS LIGHTS behind the name plate on the face of the processor. (See Figure 9 and Status Lights p. 17)
- READY LIGHT (process condition) does not illuminate when a film is in the inlet or when the film sensor is open. When the 100 PLUS is ready to process another film, the READY LIGHT will illuminate and a tone will sound.
- READY LIGHT flashes slowly when the 100 PLUS is in the overnight anticrystallization mode.

NOTE: The ready light is intended for use with x-ray films and will not fog direct exposure, blue sensitive and green sensitive films.

Reset Button

The RESET button is located behind the name plate to the right of the STATUS LIGHTS.

- The RESET button is pressed to reactivate the replenishment pumps if they were locked out.* (Turning the main circuit breaker off and then on performs the same function.)
- The RESET button is pressed to initiate one complete processing cycle. Use the RESET button to manually activate the processor should the film sensor malfunction.

*LOCK OUT: If the developer or fixer level is low, the replenishment pumps will run to refill each tank to the proper level or will run for 5 minutes, whichever occurs first. If after 5 minutes the level of either the developer or fixer is still low, the replenishment pumps are locked out. If the shutter is in the open position for more than 4 minutes, the pumps will also lock out. This feature is designed to prevent the waste of fresh chemistry.

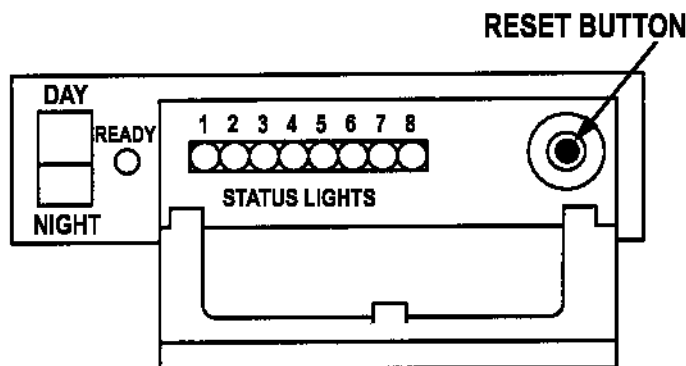

Figure 9

OPERATION

STATUS LIGHTS

These lights are located behind the name plate panel. (See Figure 9) Refer to these lights if there is a problem when operating the 100 PLUS. Review the lights, note whether there is light "on", light "off", or light "flashing". Then look in the Status column in the chart below for the explanation. For example, if READY LIGHT is not on and Light No. 4, Developer Level, is flashing, the chemistry level in the developer tank is low. A possible cause is an empty developer container, or a developer drain valve that is not completely closed.

LIGHT NO.	FUNCTION	STATUS	
1	Developer Temperature DEV TEMP	ON OFF Flashing Slowly (15 per min) Flashing Rapidly (120 per min)	Correct Low High Temperature sensor open or short circuited
2	Dryer Temperature DRYER OK	ON OFF Flashing Slowly (15 per min) Flashing Rapidly (120 per min)	Correct Low High Temperature sensor open or short circuited
3	Film Sensor FLM FEED	ON OFF Flashing	Film in inlet No film in inlet Film sensor not closing between films; replenishment pumps locked out.
4	Developer Level DEV LEVEL	ON OFF Flashing	Correct Low Low; replenishment pump unable to refill within 5 minutes; replenishment pumps locked out
5	Fixer Level FIX LEVEL	ON OFF Flashing	Correct Low Low; replenishment pumps unable to refill within 5 minutes; replenishment pumps locked out
6	Water Level WATER OK	ON OFF	Correct High or low; See Light No. 7 & 8.
7	High Water Level WATER HI	ON OFF FLASHING	Water level high See Light No 6 & 8 Water level was high
8	Low Water Level WATER LO	ON OFF	Water level low See Light No. 6

DAILY OPERATION

To insure that optimum films are delivered by the 100 PLUS, it is suggested that a Quality Control Program be adopted similar to the procedures detailed by the American College of Radiology (ACR).

At Start of Day

1. Turn the water supply valve ON.
2. Check chemistry levels in developer and fixer replenishment containers and fill as required.
3. Turn main circuit breaker ON and put DAY/NIGHT switch into DAY position.
4. In approximately 15-20 minutes, the READY LIGHT illuminates.
5. Insert a 14 x 17 cleaning film into the film inlet.

To Process Film

1. The READY LIGHT must be illuminated before film is processed.
2. Open the feed tray and slide the film into the film inlet. For all film sizes, guide the film along either edge of the feed tray. Film should enter the film inlet as straight as possible. The READY LIGHT will go out and the processor will automatically activate.
3. Before processing another film wait until the READY LIGHT illuminates and the tone sounds.
4. When the last film exits the dryer, the 100 PLUS automatically returns to standby.

At End of Day

1. Shut the water supply valve OFF.
2. If the anticrystallization cycle is to be operated overnight, put the Day/Night switch into the Night position and leave the main circuit breaker ON.
3. If the anticrystallization cycle is not to be operated overnight, turn the main circuit breaker OFF.
4. Leave the covered feed tray closed at the end of the day.

TABLE 1: FILM SERIES PROCESSING TIME

# OF FILMS IN SERIES	TOTAL DRY TO DROP PROCESSING TIME			
	17" (43cm)	14" (35cm)	12" (30cm)	10" (24cm)
1 film	2.0 min.	1.9 min.	1.8 min.	1.7 min.
2	2.5	2.4	2.3	2.2
3	3.0	2.8	2.6	2.5
4	3.6	3.3	3.0	2.8
5	4.1	3.7	3.4	3.2
6	4.6	4.2	3.8	3.5
7	5.1	4.6	4.2	3.8
8	5.6	5.1	4.6	4.2
9	6.1	5.5	4.9	4.5
10	6.7	6.0	5.3	4.8
11	7.2	6.4	5.7	5.3
12	7.7	6.9	6.1	5.7
13	8.1	7.3	6.5	6.0
14	8.7	7.8	6.9	6.4
15	9.2	8.2	7.2	6.7

SERVICE - MAINTENANCE

DAILY

Process a 14 x 17 cleaning film when the READY LIGHT illuminates to remove overnight chemistry build-up from the rollers, and to provide fresh developer and fixer to the tanks.

MONTHLY

1. Remove the developer, fixer and wash transports from the 100 PLUS and open all the drain valves (located on the front bottom of the processor) to drain all fluids from the tanks.
2. Rinse each wet transport under running water and wipe the rollers and built-in crossovers with a non-abrasive sponge. Pay close attention to the trailing edge of the crossover.
3. While holding the gears under running water, turn the main drive gear making sure that the transport rollers turn freely.

NOTE: Use non-abrasive cleaning materials ONLY on the transport rollers and crossover guides. Abrasive materials, including SCOTCH BRITE, can scratch the film guide surfaces and interfere with smooth film transport.

4. Check all rollers, o-rings, gears and turnaround guides for proper tension and to make sure the fittings are secure.
5. With all drain valves open, pour water into each tank to flush out the lines.
6. Wipe the inside surfaces of the developer, fixer and wash tanks with separate sponges. Begin with the developer tank, followed by the fixer and then the wash tank to prevent possible cross-contamination of the developer. Use only non-abrasive sponges with water or systems cleaner when cleaning the transports and tanks.
7. Flush lines again. Once the lines have completely drained, close the valves.
8. Add chemistry.

NOTE: If systems cleaner has been used, drain valves must be opened and the entire line must be thoroughly rinsed with water.

QUARTERLY

1. Perform all steps as for monthly cleaning.
2. In addition to the above, a more thorough cleaning of the transports is recommended:
 - Remove the retainer clips from all the idler studs and slide the gears off. (See Transport Assemblies, p. 49-58)
 - Clean the idler studs and gears. Replace the gears and retainer clips onto the idler studs.
 - Clean the dryer transport's bottom turnaround guide. For better access to this surface, one or both of the bottom roller pairs may be removed and then reinstalled.

This procedure should be done by a Service Technician.
3. Clean and relubricate the front-most saddle bearing, at the front end of the main drive shaft, with white lithium grease or equivalent.

SERVICE - STATUS/SERVICE DIAGNOSTIC LIGHTS

HOW TO USE THE STATUS / SERVICE DIAGNOSTIC LIGHTS

Two unique features of the 100 PLUS are the STATUS LIGHTS located behind the name plate on the front panel and the SERVICE DIAGNOSTIC LIGHTS located on the inside of the front cover.

The STATUS LIGHTS inform the operator of the temperature and fluid levels and the status of the film sensor. These lights should be reviewed first when a problem arises. The SERVICE DIAGNOSTIC LIGHTS are used by the Service Technician. Familiarity with these lights will help in pinpointing the problem area. Both sets of lights are used to gather information about the processor and then to resolve the problem.

The following relates the STATUS LIGHTS to the SERVICE DIAGNOSTIC LIGHTS during different modes: WARM-UP; STANDBY; OPEN SHUTTER; ANTICRYSTALLIZATION and NIGHT MODE. Review the summary for each chart.

WARM-UP [DAY MODE ONLY]

#9 Ready Light Off	#1 Dev Temp Off	#2 Dryer Temp Off	#3 Film Inlet Off	#4 Dev Level On (off)	#5 Fix Level On (off)	#6 Water Level Off	#7 Water High Off	#8 Water Low On
	#16 Dryer Fan Off	#15 Water Solenoid On (off)	#14 Dev Heater Off (on)	#13 Dryer Heater On (off)	#12 Drive Motor Off	#11 Recirc Pump On	#10 Repl Pump Off (on)	

Summary: Initially during warm-up, the only lights illuminated on the STATUS LIGHTS panel are the WATER LOW, DEV LEVEL, and FIX LEVEL (provided the chemistry levels are sufficient). If chemistry levels are low, the DEV LEVEL and FIX LEVEL lights will be out as well.

On the main electronics PC board, the DRYER FAN, DRIVE MOTOR, and REPL PUMP lights remain off, indicating no power is being applied to these loads during warm-up. The DRYER HEATER light will illuminate before the DEV HEATER light and then cycle once the dryer temperature has reached a set-back position. The RECIRC PUMP light will be illuminated during warm-up. The WATER SOLENOID light will be on.

SERVICE - STATUS/SERVICE DIAGNOSTIC LIGHTS

STANDBY [DAY MODE]

#9 Ready Light On	#1 Dev Temp On	#2 Dryer Temp On	#3 Film Inlet Off	#4 Dev Level On	#5 Fix Level On	#6 Water Level On	#7 Water High Off	#8 Water Low Off
	#16 Dryer Fan Off 1	#15 Water Solenoid Off (on)	#14 Dev Heater Off (on)	#13 Dryer Heater Off (on)	#12 Drive Motor Off	#11 Recirc Pump Off (on)	#10 Repl Pump Off	

Summary: On the STATUS LIGHTS panel, all temperature and chemistry level lights are illuminated, indicating conditions are correct for processing. The FILM INLET light will not illuminate until a film is entered into the processor. The WATER LEVEL light is on. As the wash tank drains via the weep hole, the WATER LEVEL light will extinguish and the WATER LOW light will illuminate when the water level goes below the low level water sensor. At this point the water solenoid opens over a predetermined amount of time and refills the wash tank.

On the main electronics PC board, the DRYER FAN, DRIVE MOTOR, and REPL PUMP service lights are off until a film is entered. The DEV HEATER and DRYER HEATER lights illuminate, indicating the processor is cycling to maintain proper temperature levels. The RECIRC PUMP light illuminates in conjunction with the DEV HEATER light indicating the movement of heated chemistry throughout the bath. The WATER SOLENOID illuminates as the wash water level is maintained.

SERVICE - STATUS/SERVICE DIAGNOSTIC LIGHTS

OPEN SHUTTER [READY MODE]

#9 Ready Light Off	#1 Dev Temp On	#2 Dryer Temp On (off)	#3 Film Inlet On	#4 Dev Level On	#5 Fix Level On	#6 Water Level On	#7 Water High Off	#8 Water Low Off
	#16 Dryer Fan On	#15 Water Solenoid On	#14 Dev Heater Off (on)	#13 Dryer Heater On (off)	#12 Drive Motor On	#11 Recirc Pump On	#10 Repl Pump On	

Summary: When the film sensor is depressed, the READY LIGHT is off while the FILM INLET light is on. The WATER HIGH and WATER LOW lights are off. The DEV TEMP, DRYER TEMP, DEV LEVEL, FIX LEVEL, and WATER LEVEL lights are all illuminated.

On the main electronics PC board, all the service lights are illuminated, indicating the loads are being powered. The DEV HEATER and DRYER HEATER will cycle to maintain temperature requirements.

SERVICE - STATUS/SERVICE DIAGNOSTIC LIGHTS

ANTICRYSTALLIZATION CYCLE

#9 Ready Light On	#1 Dev Temp On	#2 Dryer Temp On	#3 Film Inlet Off	#4 Dev Level On	#5 Fix Level On	#6 Water Level On (off)	#7 Water High Off	#8 Water Low Off (on)
	#16 Dryer Fan Off	#15 Water Solenoid Off (on)	#14 Dev Heater Off (on)	#13 Dryer Heater Off (on)	#12 #11 Drive Motor On	#10 Recirc Pump Off	Repl Pump Off (on)	

Summary: If the 100 Plus has been in STANDBY for more than ten minutes, the processor automatically activates. The rollers turn and are re-wet with the chemical solutions to prevent build-up on the rollers. The FILM INLET and WATER HIGH lights are not illuminated. The WATER LEVEL and WATER LOW will cycle on and off as wash water levels are maintained. All other STATUS LIGHTS are illuminated.

On the main electronics PC board, the DRYER FAN light is not illuminated. The WATER SOLENOID, DEV HEATER, and DRYER HEATER will cycle to maintain proper temperature and fluid levels. The REPL PUMP light will illuminate for approximately ten seconds while pumps inject fresh chemistry into the baths if the processor is set for FLOOD REPLENISHMENT. The DRIVE MOTOR will illuminate while the rollers turn.

SERVICE - STATUS/SERVICE DIAGNOSTIC LIGHTS

NIGHT MODE

#9 Ready Light Flashing	#1 Dev Temp Off	#2 Dryer Temp Off	#3 Film Inlet Off	#4 Dev Level On	#5 Fix Level On	#6 Water Level Off	#7 Water High Off	#8 Water Low On
	#16 Dryer Fan Off	#15 Water Solenoid Off	#14 Dev Heater Off	#13 Dryer Heater Off	#12 Drive Motor Off (on)	#11 Recirc Pump Off	#10 Repl Pump Off	

Summary: While in the NIGHT MODE, the READY LIGHT flashes. In addition, the WATER LOW light on the STATUS LIGHTS panel is on because the wash water will have drained from the water tank to retard the growth of algae. The DEV LEVEL and FIX LEVEL lights are on. If chemistry falls below the level of the sensors, the DEV LEVEL and FIX LEVEL will be off.

On the main electronics PC board, all the service lights, with the exception of the DRIVE MOTOR light, are not illuminated. The DRIVE MOTOR light illuminates every ten minutes indicating that rollers are turning to prevent chemistry build-up overnight.

TROUBLE SHOOTING - TABLE OF CONTENTS

The Trouble Shooting Guide is organized into three sections in a step-by-step problem solving approach. Equipment Problems deal with the installation and set-up of the processor and the mechanical problems that may occur over time with heavy usage. Film Problems and Electrical Problems require familiarity with the processor and electronics. The Film Problems section serves as the "bridge" between the Equipment and the Electrical sections since problems may first be evidenced on the processed film. The Service Technician should review the Trouble Shooting to become familiar with problems encountered and their solutions before servicing the 100 PLUS.

EQUIPMENT PROBLEMS

1. Top cover assembly not seated properly28
2. Side panels not secured properly28
3. Front panel not secure28
4. Covered feed chute not seating properly28
5. Light baffles broken / missing28
6. Condensation on film inlet tray28
7. Transport tight / squeaking / binding28
8. Films not feeding properly28
9. Noise from main drive motor28
10. Scratches / lines on films29
11. False fluid level indications29
12. Films wet or tacky29

FILM PROBLEMS

Pre-Processing Related Problems

1. Pressure marks30
2. Static30
3. Non-linear scratch marks30
4. Irregular marks30
5. Fogged film30

Processing Related Film Problems

1. Water marks / wet film30
2. Linear patterns31
3. Roller marks31
4. Dryer marks31

Chemistry-Related Film Problems

1. Changes in speed and contrast (MD/DD) values32
2. Changes in base fog (B+F)32

Exposure-Related Film Problems

1. Films32
2. Equipment32

ELECTRICAL PROBLEMS

1. Dryer too hot during the process cycle33
2. Dryer too cool or does not heat at all during the process cycle33
3. Developer chemistry is too hot34
4. Developer is too cool or does not heat during the process cycle35
5. Main drive motor does not operate during the process cycle36
6. Dryer fan does not operate during the process cycle36
7. Recirculation pump does not circulate chemistry during the process cycle36
8. Replenishment pumps do not pump when the film shutter is open37
9. Processor does not power up when main circuit breaker is turned on37
10. Water solenoid does not operate during the process cycle38
11. Process cycle does not activate when film sensor is depressed38

Equipment Problems

1. TOP COVER ASSEMBLY NOT SEATED PROPERLY

- Lift cover up and fit rear edge first, then front edge.

2. SIDE PANELS NOT SECURED PROPERLY

- Two metal clips that clip over the lower flange of the metal chassis and two spring-loaded bullet clips which snap under the side rail flanges with a fastening screw in the top front may be adjusted by loosening and repositioning. Left and right side panels are not interchangeable.

3. FRONT PANEL NOT SECURE

- Replace missing acorn nuts and / or threaded inserts.

4. COVERED FEED CHUTE NOT SEATING PROPERLY

- Remove and follow the installation procedure in Final Assembly, p. 17.

5. LIGHT BAFFLES BROKEN / MISSING

- Repair broken baffle with an epoxy adhesive.

6. CONDENSATION ON FILM INLET TRAY

- Leave film inlet tray cover closed at night.
- Run cleaning film.

7. TRANSPORT TIGHT/SQUEAKING / BINDING

- Follow monthly maintenance instructions. (See Maintenance, p. 22)
- Check all gears, o-rings, retaining clips, and bearings.
- Check for squareness. If not square, adjust by placing the transport on a flat surface and loosen the screws on the cross ties. When the transport is square, retighten the screws. Turn each main drive gear to check for free movement.

8. FILMS NOT FEEDING PROPERLY

- Check feed tray and film sensor for correct alignment.
- Feed films along one edge of feed tray.
- Guide into developer entrance rollers.
- Allow tone to sound and READY LIGHT to illuminate before feeding next film.

9. NOISE FROM MAIN DRIVE MOTOR

- Check saddle bearing at front of main drive shaft near developer transport for lubrication.
- Check main drive belt tension and adjust motor mounting plate. (See Check Drive Belt Tension, p.16)
- Check main drive motor.

SERVICE - TROUBLE SHOOTING

10. SCRATCHES / LINES ON FILMS

- Do not use abrasive materials when cleaning film guides.
- See Film Problems, p. 31-32.

11. FALSE FLUID LEVEL INDICATIONS

- If Status Light No. 4 (DEV Level) and No. 5 (FIX Level) are illuminated, but chemistry is low
 - ! Check that sensors are dry and tank walls are clean and free of any build-up.
- If Status Lights No. 4 & No. 5 do not illuminate, and pumps run until lock out occurs (5 minutes of continuous operation)
 - ! Check for open Dev / Fix drain valves.
 - ! Check that there is chemistry in replenishment containers.
 - ! Check for leaks.
- If replenishment pumps do not operate
 - ! See number 8, p. 38, for corrective action.
- If Status Light No. 8 (water Lo) remains illuminated
 - ! Check that the water supply valve is open.
 - ! Check that the wash water drain valve is closed.
- If Status Light No. 7 (Water Hi) remains illuminated
 - ! Check wash water drain lines for obstructions.
 - ! Check drain lines for proper installation. (See p. 8 & 9)
- If water solenoid does not operate
 - ! See number 10, p. 39, for corrective action.
- If fluids are found underneath tank assembly
 - ! Check all fittings.
 - ! Check bottom of tank assembly for possible fissures or cracks.
- If fluid stains are found on sides of tank assembly
 - ! Check that processor is level.

12. FILMS WET OR TACKY

- Check that water valve is open.
- Check that the water solenoid is functional. (See number 10, p. 39)
- Check wash water hose for leaks or blockage.
- Check fixer replenishment and chemical activity.
- Check that processor is level.

FILM PROBLEMS

Developed x-ray film is useful in identifying radiographic quality problems that are related to the processing cycle. Examine the film for telltale marks and signs. Then look below to identify the problem which could be related to any of the following: Pre-Processing, Processing, Chemistry or Exposure.

PRE-PROCESSING RELATED FILM PROBLEMS

1. Pressure marks

- Plus densities due to rough handling prior to exposure and processing.
- Minus densities due to rough handling after exposure and prior to processing.
- Avoid bending and flexing film prior to and after processing.

2. Static

- Plus densities due to electric discharge on film surface; may be "tree" static or "smudge" static.
 - ! Maintain proper level of (30-50%) humidity in the darkroom.

3. Non-linear scratch marks

- Minus densities due to emulsion being scraped from substrate.
 - ! Avoid placing film on rough surfaces and/or sliding film.

4. Irregular marks

- Minus densities due to particles on surfaces of intensifying screens or pick-off from rollers.
 - ! Use screen cleaner with a lint-free gauze pad or other lint-free cloth, as recommended by screen manufacturers.

5. Fogged film

- Plus densities due to darkroom light leaks or film exposed to light.
 - ! Perform light leak test for darkroom.
- Plus densities due to improper safelight or prolonged safelight exposure.
 - ! Follow film manufacturer's recommendation for proper safe lighting.
- Plus densities due to outdated or improperly stored film.
 - ! Replace outdated film.

PROCESSING RELATED FILM PROBLEMS

1. Water marks/wet film

- Dark, crescent-shaped marks generally seen only in reflective light and found on the leading edge of the film.
- Dark spots, generally seen only in reflective light, may exhibit a line running back towards the trailing edge of the film.
 - ! Overall film wet/tacky to touch.

For all of the above conditions check the following:

- ! Check o-ring tension on wash/dryer exit/entrance roller pairs.
- ! Check wash water overflow and drain line for blockage.
- ! Check high water level sensor.
- ! Check dryer setting and lamp resistance.
- ! Check dryer thermistor.
- ! Check that processor is level.

SERVICE - TROUBLE SHOOTING

2. Linear patterns

- Plus density lines, approximately 1/8" apart: running in direction of film travel. Generally caused by film contact with the curved guide in the developer transport or developer/fixer crossover. Lines are seen in transmitted light and are on the top side of the film.
 - ! Check alignment of guides to roller nip.
 - ! Check guides for burrs.
- Minus density lines, approximately 1/8" apart; running in direction of film travel. Generally caused by contact with fixer/wash/dry transports cross-overs, dryer bottom turnaround, or flat guide in dryer. Lines are seen in reflected and/or transmitted light and can be on either surface of film.
 - ! Check guides for burrs.
 - ! Identify top/bottom side of film.
 - Top side:* check alignment of guides to roller nip between transports.
 - Bottom side:* check alignment of bottom turnaround and flat guide to respective roller pair nip.

3. Roller marks

- Plus density lines running perpendicular to film travel and repeating the length of the film. Generally caused by developer rollers that are not straight or by gear interference.
 - ! Clean rack assembly.
 - ! Check for missing o-rings and/or correct transport tension.
 - ! Check for correct roller pairing in transport, ie. rubber/rubber, rubber/plastic or plastic/plastic.
 - ! Check gaps between rollers in each pair.
- Plus density lines running the length of the film which vary in size and distance from each other. Generally caused by developer rollers that have high or low spots around the circumference of the roller.
 - ! Check for correct roller pairing in rack ie. rubber/rubber, rubber/plastic or plastic/plastic.
 - ! Check for gaps between rollers in each pair.

4. Dryer marks

- Triangular marks found on trailing edge of film. Generally seen in both transmitted and reflected light. Referred to as lamp guard heat marks.
 - ! Check for burrs on lamp reflector.
 - ! Check position of lamp guards.
 - ! Check lamp guard alignment.
- Diffuse lines, approximately 1/8" apart and seen in reflected lighting in direction of film feed. Generally found on top side of film. Referred to as heat marks from dryer crossover.
 - ! Check dryer rack alignment.
 - ! Check for burrs on guides.
 - ! Lower dryer temperature.
- Diffuse pattern, plus density. Generally seen in reflected and transmitted light. Referred to as "shore lining".
 - ! Lower dryer temperature.
 - ! Check dryer air boots.
 - ! Check wash water level.
 - ! Check for correct roller pairing in wash/dry exit/entrance rollers.
 - ! Check that processor is level.

CHEMISTRY-RELATED FILM PROBLEMS

Consult film and chemistry manufacturers specifications for recommended temperature, replenishment rates, and developer immersion times prior to troubleshooting the 100 Plus.

1. Changes in speed and contrast (MD/DD) values

- Sensitometry results above or below acceptable range typically result from:
 - ! Developer temperature too high/low.
 - ! Replenishment rates too high/low.
 - ! Developer solution “hot” or exhausted.
 - ! Change in film lot/brand/type.
 - ! Change in chemistry brand.
 - ! Processing cycle too long/short.

2. Changes in base fog (B+F)

- Sensitometry results ABOVE acceptable values typically result from:
 - ! Change in film lot/brand/type.
 - ! Age of film.
 - ! Exposure to light /ionizing radiation.
 - ! Developer temperature too high.
 - ! Over-replenishment.
 - ! Inadequate storage.

EXPOSURE-RELATED FILM PROBLEMS

1. Films

- Over/under exposed:
 - ! Exposure techniques incorrect.
 - ! Change in film/screen combination.
 - ! Use of beam-restricting devices, ie. grids.

2. Equipment

- Test x-ray equipment for:
 - ! Incomplete exposures.
 - ! Decreased mR output.
 - ! Inadequate line voltages.

SERVICE - TROUBLE SHOOTING

Electrical Problems

WARNING!

Tests in this section must be performed only by qualified service technicians. Safety interlocks will be bypassed and hazardous voltages will be present.

To perform many of the tests detailed below, remove the top cover and “defeat” the interlock switch. This is accomplished by inserting the blade of a screwdriver into the interlock switch opening. Point the blade toward the rear of the processor when inserting.

When resistance or continuity is to be tested, we recommend that the processor be unplugged from its electrical receptacle.

1. DRYER TOO HOT DURING THE PROCESS CYCLE

QUICK CHECK: Led #2 Not Flashing

If the air from the dryer, or the dryer exit rollers appear to be very hot while Status Light No. 2 (DRYER TEMP) is on, the dryer potentiometer may simply be set too high. Turn it down. If the light is flashing, follow the procedure below.

Check SERVICE DIAGNOSTIC LIGHT # 13 [DRY].

- A. If light is flashing test voltage at dryer connector between pins 1 and 2 (yellow and brown wires) for 115 VAC.

Perform this test with the connector plugged in. (See Table 2, p. 39)

1. If 115 VAC is present and pulses in synch with light, measure dryer heater lamp resistance at dryer connector between pins 1 and 2 (yellow and brown wires).
 - a. *If resistance is 22.5 ohms or 45 ohms, replace defective lamp(s).*
 - b. *If resistance is 15 ohms, lamps are OK. Turn dryer potentiometer setting down.*
2. If 115 VAC is present but does not pulse, test voltage between J2-3 and J2-5 for 115 VAC.
 - a. *If voltage stays less than 50 VAC, replace main PC board assembly.*
 - b. *If voltage pulses in synch with light or remains 115 VAC, replace triac.*

CAUTION: Do not turn on processor unless all three terminals are securely attached to triac. Otherwise, main PC board assembly will be severely damaged!

- B. If light is constant measure dryer thermistor resistance. Disconnect connector J1 from main PC board assembly and measure between pins 9 and 10 (yellow and white wires).

(See Table 3, p. 40) .

1. If in tolerance, replace main PC board assembly.
2. If out of tolerance, measure dryer thermistor resistance at dryer connector between pins 5 and 6 (black and red wires).
 - a. *If out of tolerance, replace thermistor.*
 - b. *If in tolerance, check for poor connections in thermistor circuit between connector J1 and dryer connector.*

2. DRYER TOO COOL OR DOES NOT HEAT AT ALL DURING THE PROCESS CYCLE.

QUICK CHECK

If the films exiting the dryer are slightly damp or tacky to the touch, and Status Light No. 2 (DRYER TEMP) is off, the dryer potentiometer may simply be set too low. Turn it up. If the light remains out, follow the procedure below.

Check SERVICE DIAGNOSTIC LIGHT # 13 (DRY).

- A. If light is flashing or on constantly, test voltage at dryer connector between pins 1 and 2 (yellow and brown wires).

Perform this test with the connector plugged in.

1. If no voltage is present, test voltage between J2-3 and J2-5 for 115 VAC.
 - a. *If voltage is constant at 115 VAC, replace main PC board assembly.*
 - b. *If voltage pulses or is less than 50 VAC, replace triac.*

CAUTION: Do not turn on processor unless all three terminals are securely attached to triac. Otherwise, main PC board assembly will be severely damaged!

2. If 115 VAC is present and pulses in synch with light, measure dryer heater lamp resistance at dryer connector between pins 1 and 2 (yellow and brown wires).
 - a. *If resistance is 22.5 ohms or 45 ohms, replace defective lamp(s).*
 - b. *If resistance is 15 ohms, lamps are OK. Turn dryer potentiometer setting up.*

- B. If light does not illuminate, turn dryer potentiometer up. If light still does not illuminate, measure dryer thermistor resistance. Disconnect connector J-1 from main PC board assembly and measure between pins 9 and 10. (See Table 3, p. 40)
1. If in tolerance, replace main PC board assembly.
 2. If out of tolerance, measure dryer thermistor resistance at dryer connector between pins 5 and 6.
 - a. *If out of tolerance, replace thermistor.*
 - b. *If in tolerance, check for poor connections in thermistor circuit between connector J-1 and dryer connector.*

3. DEVELOPER CHEMISTRY IS TOO HOT

QUICK CHECK

If the processed films are too dark, and Status Light No. 1 is on, developer temperature may be set too high. Measure developer temperature and turn down if necessary. If temperature remains high, follow the procedure below.

Check SERVICE DIAGNOSTIC LIGHT # 14 [DEV].

- A. If light is flashing test voltage between TB2-3 and TB 1-3 for 115 VAC.
1. If 115 VAC is present and pulses in synch with light, developer temperature may be set too high. Measure and turn down if necessary. (See Set Developer Temperature, p.13)
 2. If 115 VAC is present but does not pulse, test voltage between J2-1 and J2-2 for 115 VAC.
 - a. *If voltage stays less than 50 VAC, replace main PC board assembly.*
 - b. *If voltage pulses with light, replace triac PIN 115578.*

CAUTION: Do not turn on processor unless all three terminals are securely attached to triac. Otherwise, main PC board assembly will be severely damaged!

SERVICE - TROUBLE SHOOTING

- B.** If light is on constantly, measure developer thermistor resistance. Disconnect J1 from the main PC board assembly and measure between pins 11 and 12. (See Table 3. p. 41)
1. If out of tolerance, replace thermistor.
 2. If in tolerance, replace main PC board assembly.

4. DEVELOPER IS TOO COOL OR DOES NOT HEAT DURING THE PROCESS CYCLE.

QUICK CHECK

If the films are underdeveloped, and Status Light No. 1 is on, developer temperature may be set to low. Measure developer temperature and increase if necessary.

If Status Lights No. 1 and 4 are off, developer chemistry level may be low, and will not heat as a result. Add chemistry, then press Reset button or turn main circuit breaker on and off to initiate the process cycle. If temperature does not increase and there is chemistry in the tanks, follow the procedure below.

Check SERVICE DIAGNOSTIC LIGHT # 14 [DEV].

- A.** If light is flashing or on constantly, test voltage between J2-2 and J2-5 for 115 VAC.
1. If voltage pulses or is constant, check voltage between TB2-3 and TB1-3 for 115 VAC.
 - a. *If no voltage is present, check connections at TB1 and TB2.*
 - b. *If voltage is present, measure developer heater resistance.*
! If resistance is not 26 ohms, replace developer heater.
 2. If no voltage is present, test voltage between J2-1 and J2-2 for 115 VAC.
 - a. *If voltage is constant at 115 VAC, replace main PC board assembly.*
 - b. *If voltage pulses or is less than 50 VAC, replace triac.*

CAUTION: Do not turn on processor unless all three terminals are securely attached to triac. Otherwise, main PC board assembly will be severely damaged!

- B.** If light does not illuminate, turn developer potentiometer up. (See Set Developer Temperature, p. 11) If it still does not illuminate, measure developer thermistor resistance. Disconnect connector J1 from main PC board assembly and measure between pins 11 and 12. (See Table 3, p. 40)
1. If out of tolerance, replace thermistor.
 2. If in tolerance, replace main PC board assembly.

5. MAIN DRIVE MOTOR DOES NOT OPERATE DURING THE PROCESS CYCLE

Check SERVICE DIAGNOSTIC LIGHT # 12 [DRIVE].

- A. If light is not illuminated, replace main PC board assembly.
- B. If light is illuminated, test voltage between J2-8 and TB2-2 for 115 VAC.
 - 1. If no voltage is present, check TB2-2 connection. If connection is good, replace main PC board assembly.
 - 2. If 115 VAC is present, test voltage between TB1-2 and TB2-2 for 115 VAC.
 - a. *If no voltage is present, check connection at TB1 -2.*
 - b. *If 115 VAC is present, replace main drive motor.*

6. DRYER FAN DOES NOT OPERATE DURING THE PROCESS CYCLE

Check SERVICE DIAGNOSTIC LIGHT # 16 [FAN].

- A. If light is not illuminated, replace main PC board assembly.
- B. If light is illuminated, test voltage between J2-11 and TB2-2 for 115 VAC.
 - 1. If no voltage is present, check TB2-2 connection. If connection is good, replace main PC board assembly.
 - 2. If 115 VAC is present, test voltage between TB1-5 and TB2-2.
 - a. *If no voltage is present, check connection at TB1-5.*
 - b. *If 115 VAC is present, replace fan.*

7. RECIRCULATION PUMP DOES NOT CIRCULATE CHEMISTRY DURING THE PROCESS CYCLE.

QUICK CHECK

If chemistry circulates in the developer and not the fixer, or vice versa, the circulator motor is operating but one side of the pump has a mechanical problem. Check for blockages in the recirculating lines. If there is a blockage, pour warm water into the pump inlet. If the blockage still does not clear, replace the pump assembly.

If there is no blockage, follow the procedure below.

Check SERVICE DIAGNOSTIC LIGHT # 11 [CIRC].

- A. If light is not illuminated, replace main PC board assembly.
- B. If light is illuminated, test voltage between J2-9 and TB2-1.
 - 1. If no voltage is present, check connection at TB1-4.
 - 2. If 115 VAC is present, replace recirculation pump assembly.

SERVICE - TROUBLE SHOOTING

8. REPLENISHMENT PUMPS DO NOT PUMP WHEN THE FILM SHUTTER IS OPEN.

QUICK CHECK

Check Status Lights Nos. 4 and 5. If one or the other light is flashing, replenishment pumps are locked out. This means that the processor has unsuccessfully tried to fill tanks for 5 minutes. If the replenishment containers are empty, fill them. If the drain valves are open, close them. To reset replenishment pumps, turn main circuit breaker off and on. If the pumps still do not run. Follow the procedure below.

Check SERVICE DIAGNOSTIC LIGHT # 10 [REPL].

- A. If light is not illuminated, replace main PC board assembly.
- B. If light is illuminated but pumps do not operate, test voltage between J2-10 and TB2-2 for 115 VAC with shutter open.
 - 1. If no voltage is present, check TB1-1 connection. If connection is good, replace main PC board assembly.
 - 2. If 115 VAC is present, test voltage between TB1-1 and TB2-2 for 115 VAC.
 - a. *If no voltage is present, check connection at TB1-1.*
 - b. *If 115 VAC is present, replace replenishment pump.*
- C. If light is illuminated and pumps operate, but no chemistry is being pumped
 - 1. Check replenishment containers. If empty, fill.
 - 2. Check replenishment tubing. If kinked or bent, straighten.
 - 3. Check pump valves. If dirty, clean.

9. PROCESSOR DOES NOT POWER UP WHEN MAIN CIRCUIT BREAKER IS TURNED ON.

QUICK CHECK

Check that there is electrical power to the outlet and that the processor is plugged in. If the processor does not power up, follow the procedure below.

Check THE TRIPPER POST: REMOVE THE TOP COVER AND DEFEAT THE INTERLOCK SWITCH (See Warning, p.33]

- A. If processor powers up, determine why tripper post in top cover does not activate interlock switch.
- B. If processor does not power up, disconnect plug from power receptacle. Test interlock switch and main circuit breaker for continuity. If defective, replace.
- C. If interlock switch and main circuit breaker are OK, test voltage between J2-5 and J2-6 for 115 VAC.
 - 1. If no voltage is present, test all terminals and wiring from TB-4 to J2-5 and J2-6.
 - 2. If 115 VAC is present, replace fuse on main PC board assembly.
 - 3. If this does not solve problem, replace main PC board assembly.

10. WATER SOLENOID DOES NOT OPERATE DURING THE PROCESS CYCLE.

QUICK CHECK

Be sure that the water supply valve is turned on and that the screen filter at the solenoid entry is not clogged. If the water solenoid still does not turn on, follow the procedure below.

CHECK STATUS LIGHT NO. 7 [WATER HIGH] AND NO. 6 [WATER LEVEL]

- A.** If No. 7 is illuminated, the water solenoid is locked out. Disconnect the wire from terminal J1-7.
1. If No. 7 flashes and No. 6 comes on
 - a. *Check for wet level sensor.*
 - b. *Check for accidental grounding of level sensor.*
 - c. *Check drain line blockage or air locks.*
 2. If No. 7 remains illuminated, replace main PC board assembly.
Don't forget to reconnect wire to terminal J1-7.
- B.** If No. 6 is illuminated, check Service Diagnostic Light #15 (WAT).
1. If light is not illuminated, replace main PC board assembly.
 2. If light is illuminated, test voltage between J2-12 and TB2-2 for 115 VAC.
 - a. *If no voltage is present, change main PC board assembly.*
 - b. **If 115 VAC is present, check for 115 VAC at solenoid terminals.**
 - * If 115 VAC is present, change solenoid.
 - ** If no voltage is present, check wiring and connections.

11. PROCESS CYCLE DOES NOT ACTIVATE WHEN FILM SENSOR IS DEPRESSED.

CHECK STATUS LIGHT NO. 3 [FILM INLET]

- A.** If light illuminates when film sensor is depressed, replace main PC board assembly.
- B.** If light does not illuminate when film sensor is depressed, test voltage between J1-1 and J1-3 for 5 VDC.
1. If no voltage is present, replace main PC board assembly.
 2. If 5 VDC is present, test voltage between J1-2 and J1-3 for 5 VDC with film sensor depressed.
 - a. If 5 VDC is present, replace main PC board assembly.
 - b. If no voltage is present
 - * Check electrical connections to film sensor PC board.
 - ** Check that film sensor flag withdraws from inside optic sensor when film sensor is depressed.
 - ! If film sensor flag operates correctly, replace film sensor PC board assembly.

SERVICE - TROUBLE SHOOTING

TABLE 2: VOLTAGE AND RESISTANCE VALUES

Loads	Test Points	Voltage 115 VAC 12A 50/60 Hz	Resistance
Main Drive Motor	J2-8 to TB2-2 TB1-2 to TB2-2	115 VAC 115 VAC	
Dryer Heater	DRYER CONNECTOR PINS 1 & 2 J2-3 to J2-5 w/SERVICE LED ON J2-3 to J2-5 w/SERVICE LED ON J1-9 to J1-10 THERMISTOR PINS 5 & 6 (black and red wires)	115 VAC 115 VAC 115 VAC	15 ohms See Table 3
Dryer Fan TB1-5 to TB2-2	J2-11 to TB2-2 115VAC	115VAC	
Developer Heater	TB2-3 to TB1-3 J2-1 to J2-2 w/SERVICE LED OFF J2-2 to J2-5 w/SERVICE LED ON THERMISTOR J1-11 to J1-12	115 VAC 115 VAC 115 VAC	26 ohms See Table 3
Recirc Pump	J2-9 to TB2-1 TB1-4 to TB2-1	115 VAC 115 VAC	
Replenishment Pumps	TB1-1 to TB2-2 J2-10 to TB2-2	115 VAC 115 VAC	
Water Solenoid Hi Level Sensor Lo Level Sensor	J2-12 to TB2-2 J1-7 to ground J1-6 to ground	115 VAC	infinity infinity
Interlock Switch	J2-5 - J2-6	115 VAC	
Film Sensor PC Board	J1-1 - J1-3 J1-2 - J1-3 w/SENSOR ACTIVATED	5 VDC 5 VDC	

SERVICE - TROUBLE SHOOTING

TABLE 3: THERMISTOR TEMPERATURE / RESISTANCE VALUES	
Temperature (°F)	Resistance (ohms)
80	4735
85	4150
90	3710
95	3288
100	2940
110	2534
120	2143
130	1875
140	1450

PARTS / ASSEMBLIES - Table of Contents

100 PLUS EXTERIOR42-43
100 PLUS INTERIOR44-45
FILM SENSOR ASSEMBLY46
CHASSIS BULKHEAD47
DEVELOPER TRANSPORT48-49
FIXER TRANSPORT50-51
WASH TRANSPORT52-53
DRYER TRANSPORT54-57

PARTS / ASSEMBLIES

100 Plus Exterior

ITEM No.	DESCRIPTION	PART No.
1	Top Cover Assembly	47110
2	Side Panel Assembly, Right	47220
3	Side Panel Assembly, Left	47230
4	Electronics Enclosure Assembly, 115v	47520
5	Bracket, Side Panel	49124
6	Catch, Bullet, Side Panel	49161
7	Locking Tab	49206
8	Screw, Side Panel Lock	30405
9	Valve, Developer Drain Assembly	47141
10	Valve, Fixer Drain Assembly	47142
11	Valve, Wash Weep / Drain Assembly	47143
12	Diagnostic Door Assembly	47028
13	Circuit Breaker, 15 Amp	49511

NOT ILLUSTRATED

Dryer Blower, 115V	49846
Solenoid Valve Assembly, 115v, Water Inlet	47450
Power Cord, 115v	49411
Developer Replenishment Container	47053
Fixer Replenishment Container	47054
Developer Chemistry Floating Lid	47712
Water Inlet Hose, Right Angle	49166
Wall Chart	49102
Manual & Binder, 100 Plus	47104
Gasket, Top Cover	47122
Feed Tray Assembly (see p.17 for illus.)	47190

PARTS / ASSEMBLIES

100 Plus Exterior

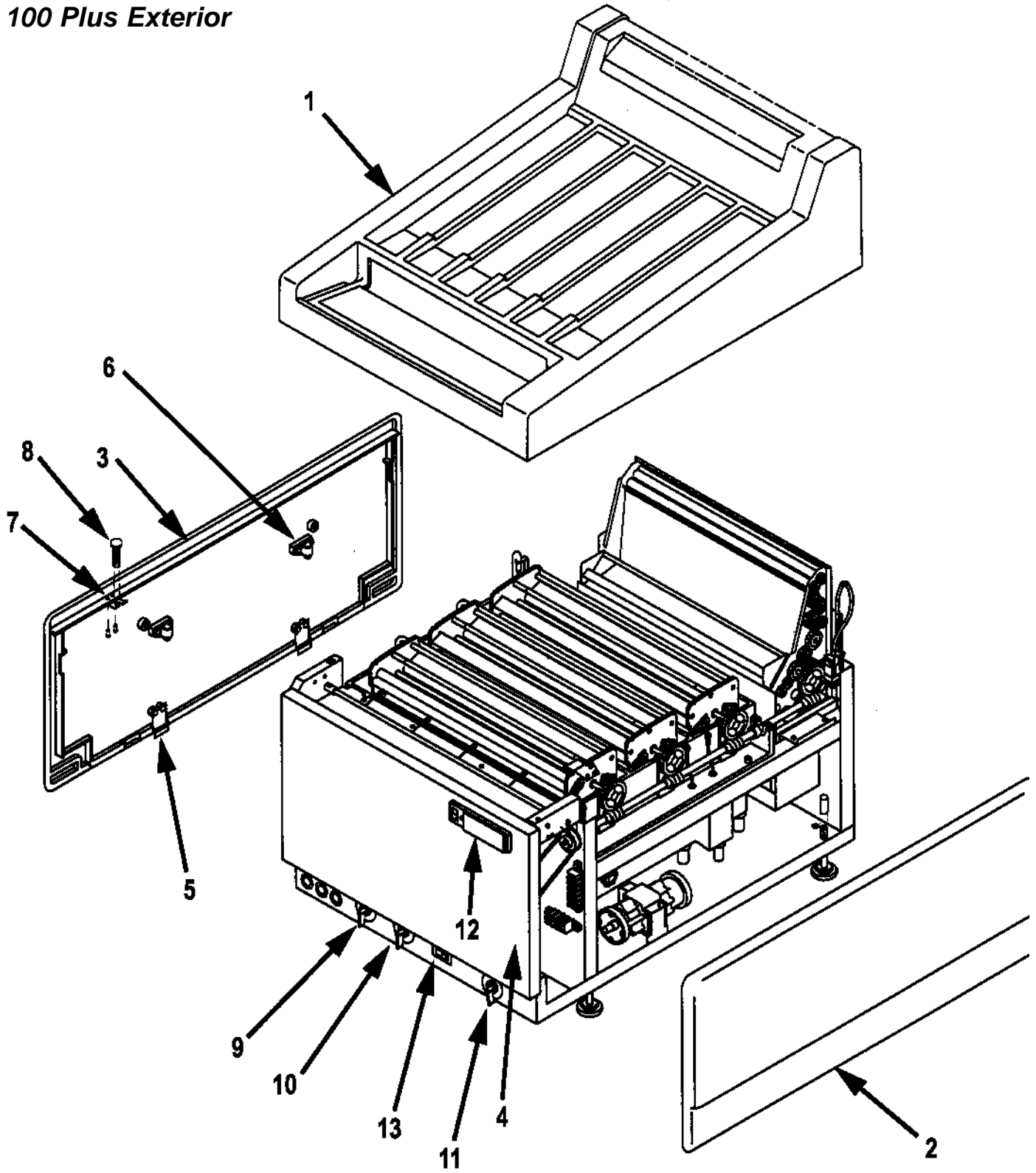

100 Plus Interior

ITEM No.	DESCRIPTION,	PART No.
1	Developer Transport Assembly47810
2	Fixer Transport Assembly47820
3	Wash Transport Assembly47830
4	Dryer Transport Assembly, 115v47750
5	Tank, Drilled47302
6	Drive Shaft Assembly49120
7	Replenishment Tube49142
8	Leveling Foot43106
8A	Sleeve, Leveling Foot47848
9	Heater, Developer, 115v49336
10	Recirculator Pump, Dual Head, 115v47314
11	Splash Guard Assembly47163
12	Bearing, Saddle49307
13	Bracket, Wash Tube Support47124
14	Panel, Dryer Support / Locator47727
15	Dryer, Rear Support Assembly47737
16	Bracket, High Level Sensor47318
17	Control PC Board Assembly, 115v49500
18	Cover, PC Board Protector49126

PARTS / ASSEMBLIES

100 Plus Interior

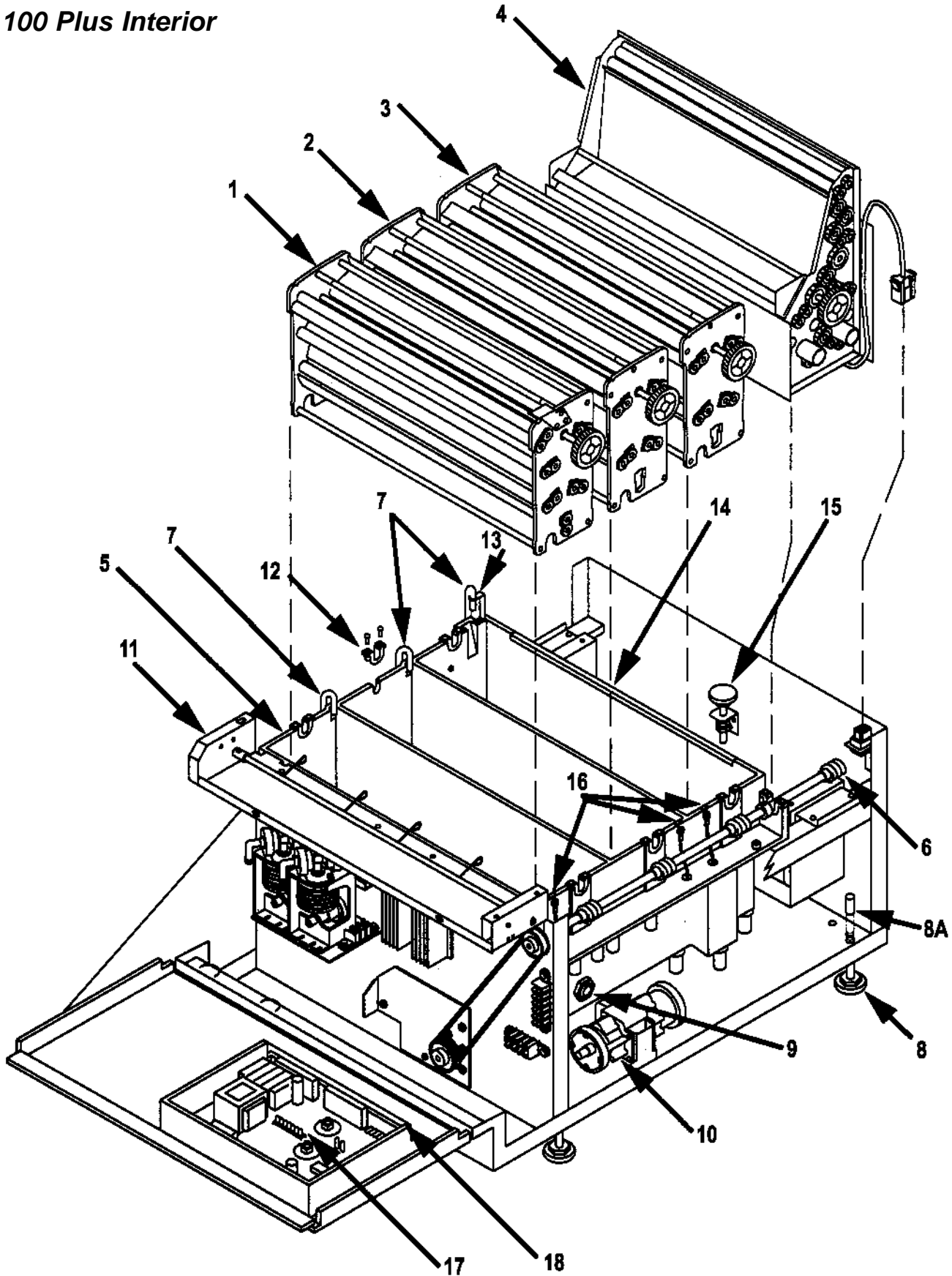

Film Inlet Assembly

ITEM No.	DESCRIPTION	PART No.
1	Film Sensor Actuator Assembly	.47798
2	Coupling, Right	.47181
3	Coupling, Left	.47182
4	Splash Guard	.47199
5	Cover, Interlock Switch	.47184
6	Cover, Film Sensor	.47185
7	Interlock Switch	.47519
8	PC Board Assembly, Film Sensor	.47540
9	Actuator, Film Sensor	.47465

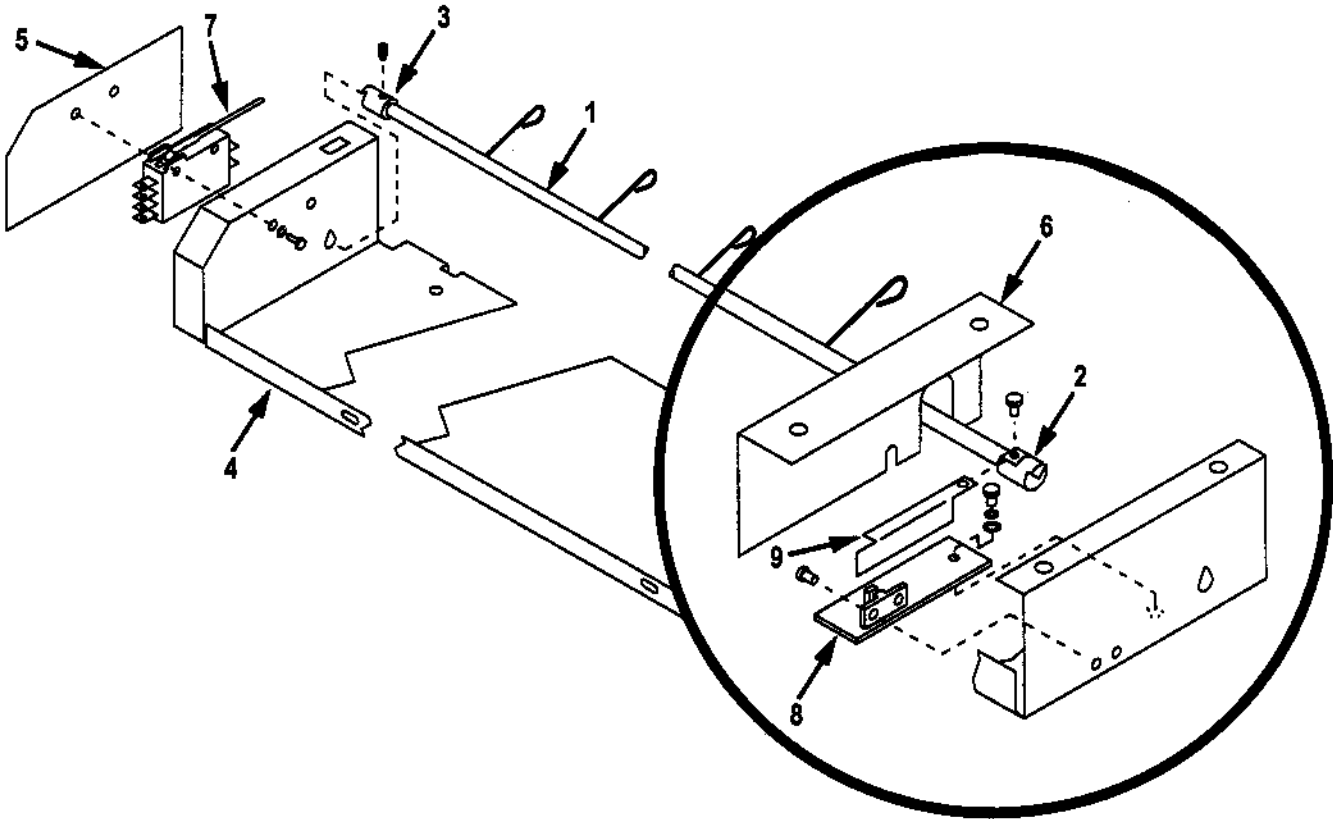

PARTS / ASSEMBLIES

Chassis Bulkhead

ITEM No.	DESCRIPTION	PART No.
1	Replenisher Pump Ass'y, 115v	49880
2	Thermistor Assembly, Developer	47335
3	Drive Motor Assembly (Includes Mounting Plate, Drive Motor, Pulley & Fan) . . .	49461
4	Pulley, 28 Tooth	49417
5	Timing Belt, 133 Tooth	49241
6	Pulley, 24 Tooth	49418
7	Heat Sink Assembly, Includes Triacs	49408
8	Triac, 600v, 25 Amp	115578
9	Drive Motor Replacement Kit, 115v	49301
10	Drive Motor Cooling Fan	49427
11	Ring, Retaining	30840

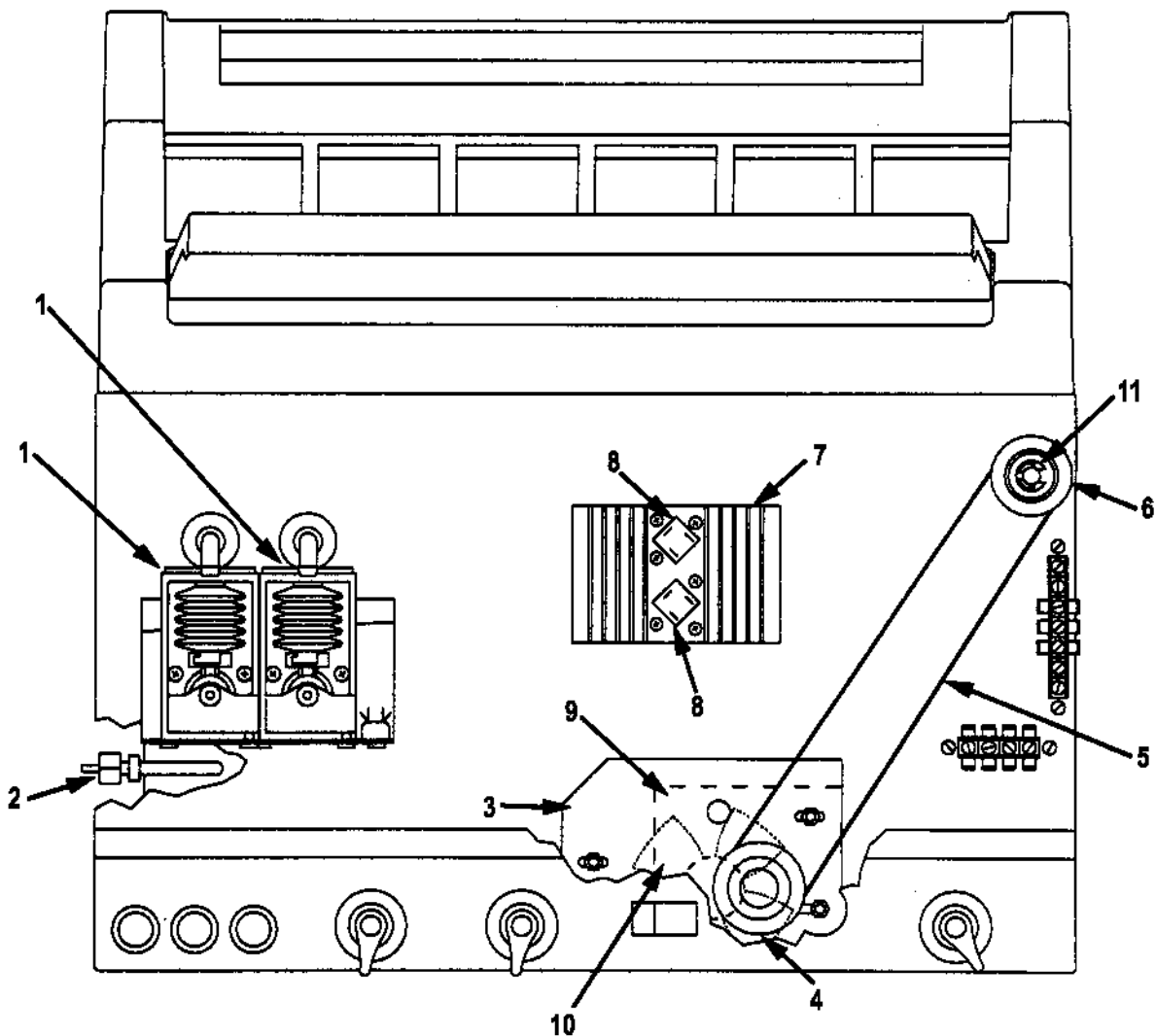

Developer Transport

ITEM No.	DESCRIPTION	PART No.
1	Bushing, Roller Spring	49811
2	Bushing, Roller Spring, Square	49831
3	O-Ring, Size 120	49823
4	Retainer Clip, Roller Shaft, 1/4"	49807
5	Retainer Clip, Idlers/Drive Shaft, 3/8"	49808
6	Stud, Idler.....	49822
7	Bearing, 3/8", Nylon.....	49816
8	Pin, Cotter, 1/16" x 1" Lg.....	30798
9	Pin, Cotter, 1/16" x 1-1/2" Lg	30799
10	Drive Shaft Rod	49817
11	Gear, worm	49818
12	Gear, Spur, .75" P.D., 'D' Bore.....	49801
13	Gear, Spur, 1.25" P.D., 3/8" Bore	49802
14	Gear, Drive, 1.5" P.D., 3/8" Bore	49803
15	Roller, Rubber, Standard, Black Color	49828
17	Guide, Flat, Film Transport	49815
18	Guide, Curved, Film Transport.....	49814
19	Cross Tie, Wet Transport	49827
20	Guide, Crossover, In/Out, Film Transport	47868
21	Gear, Spur, 2.0" P.D., 3/8" Bore.....	49804
22	Collar.....	30800
23	Gear, Spur, .75" P.D., 3/8" Bore.....	49805
26	Side Plate, Developer Transport.....	47836
28	Bracket, Feedtray Hold Down	47123

PARTS / ASSEMBLIES

Developer Transport

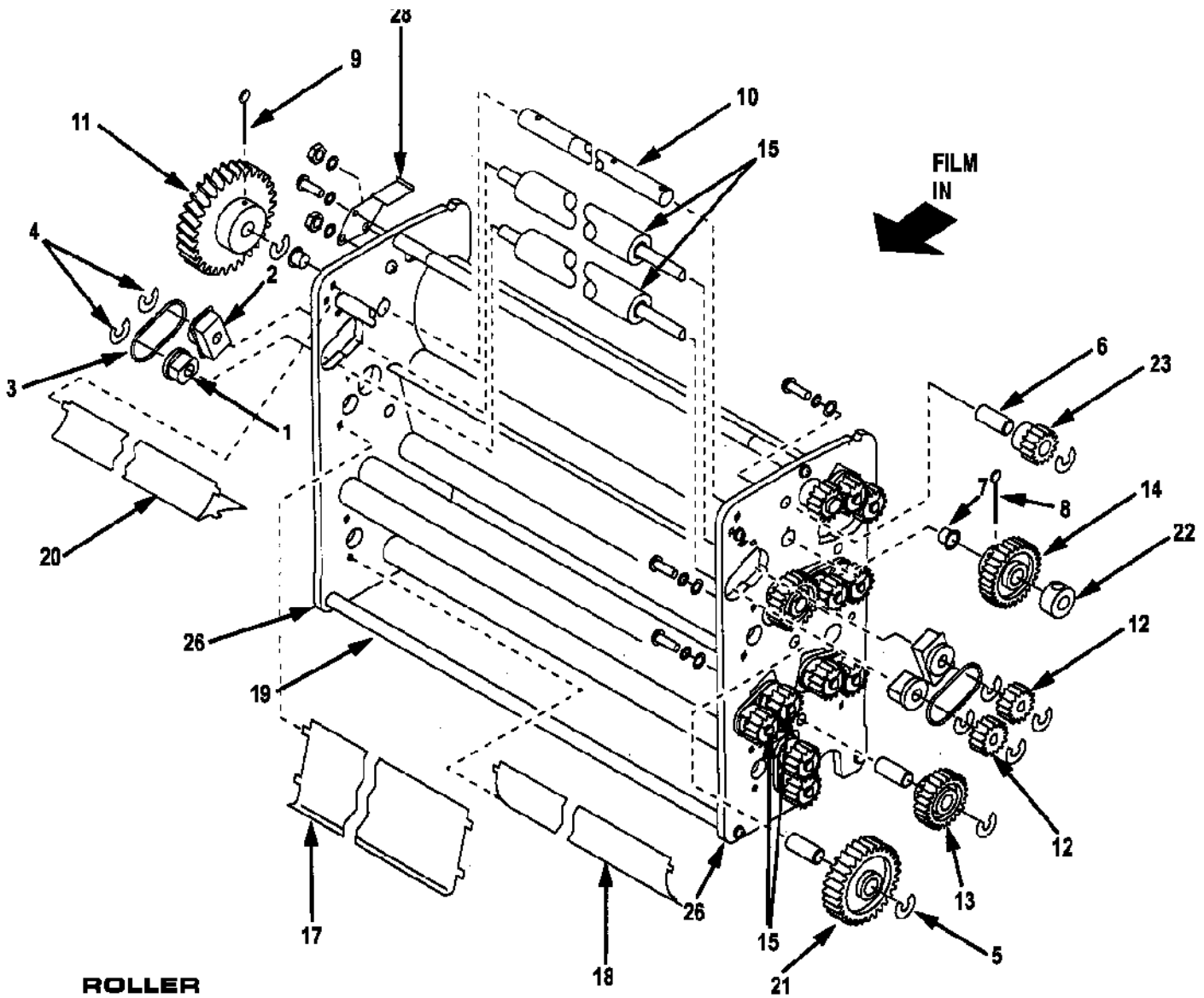

ROLLER IDENTIFICATION

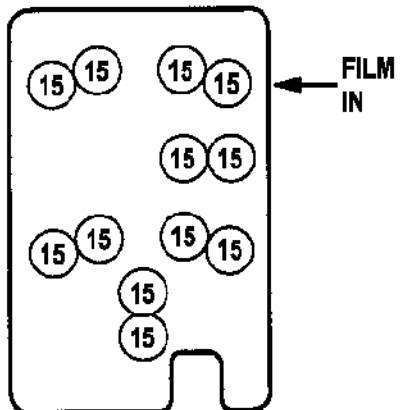

Fixer Transport

ITEM No.	DESCRIPTION	PART No.
1	Bushing, Roller Spring.....	49811
2	Bushing, Roller Spring, Square.....	49831
3	O-Ring, Size 120	49823
4	Retainer Clip, Roller Shaft, 1/4”.....	49807
5	Retainer Clip, Idlers/Drive Shaft, 3/8”.....	49808
6	Stud, Idler	49822
7	Bearing, 3/8”, Nylon	49816
8	Pin, Cotter, 1/16” x 1” Lg	30798
9	Pin, Cotter, 1/16” x 1-1/2” Lg.....	30799
10	Drive Shaft Rod.....	49817
11	Gear, Worm.....	49818
12	Gear, Spur, .75” P.D., 'D' Bore	49801
13	Gear, Spur, 1.25” P.D., 3/8” Bore	49802
14	Gear, Drive, 1.5” P.D., 3/8” Bore.....	49803
15	Roller, Rubber, Standard, Black Color.....	49828
16	Roller, Plastic, Golden Color	49872
17	Guide, Flat, Film Transport.....	49815
18	Guide, Arched, Film Transport.....	49824
19	Cross Tie, Wet Transport.....	49827
20	Guide, Crossover, In/Out, Film Transport	47868
21	Gear, Spur, 2.0” P.D., 3/8” Bore	49804
22	Collar	30800
26	Side Plate, Fixer / Wash Transport.....	47837

PARTS / ASSEMBLIES

Fixer Transport

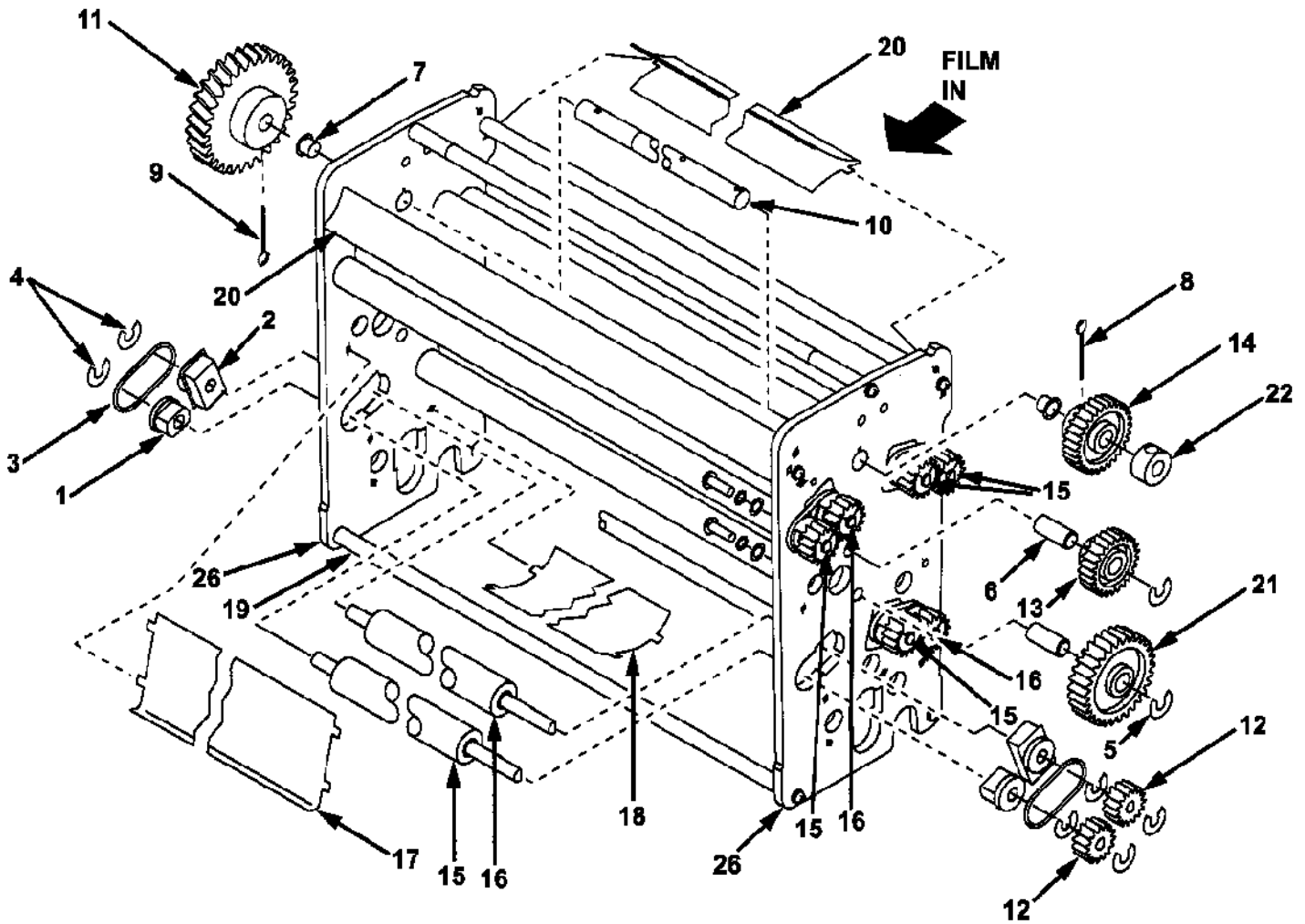

ROLLER IDENTIFICATION

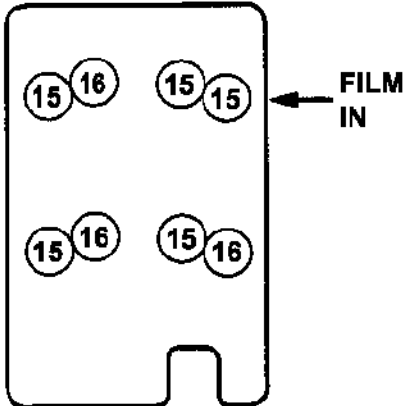

Wash Transport

ITEM No.	DESCRIPTION	PART No.
1	Bushing, Roller Spring.....	49811
2	Bushing, Roller Spring, Square.....	49831
3	O-Ring, Size 120	49823
4	Retainer Clip, Roller Shaft, 1/4”.....	49807
5	Retainer Clip, Idlers/Drive Shaft, 3/8”.....	49808
6	Stud, Idler	49822
7	Bearing, 3/8”, Nylon	49816
8	Pin, Cotter, 1/16” x 1” Lg	30798
9	Pin, Cotter, 1/16” x 1-1/2” Lg.....	30799
10	Drive Shaft Rod.....	49817
11	Gear, Worm.....	49818
12	Gear, Spur, .75” P.D., 'D' Bore	49801
13	Gear, Spur, 1.25” P.D., 3/8” Bore	49802
14	Gear, Drive, 1.5” P.D., 3/8” Bore.....	49803
15	Roller, Rubber, Standard, Black Color.....	49828
16	Roller, Plastic, Golden Color	49872
17	Guide, Flat, Film Transport.....	49815
18	Guide, Arched, Film Transport.....	49824
19	Cross Tie, Wet Transport.....	49827
20	Guide, Crossover, In/Out, Film Transport	47868
21	Gear, Spur, 2.0” P.D., 3/8” Bore	49804
22	Collar	30800
24	Roller, Rubber Squeege, Black Color.....	49835
22	Guide, Croosover, Wash Outlet, Film Transport.....	47869
26	Side Plate, Fixer / Wash Transport.....	47837

PARTS / ASSEMBLIES

Wash Transport

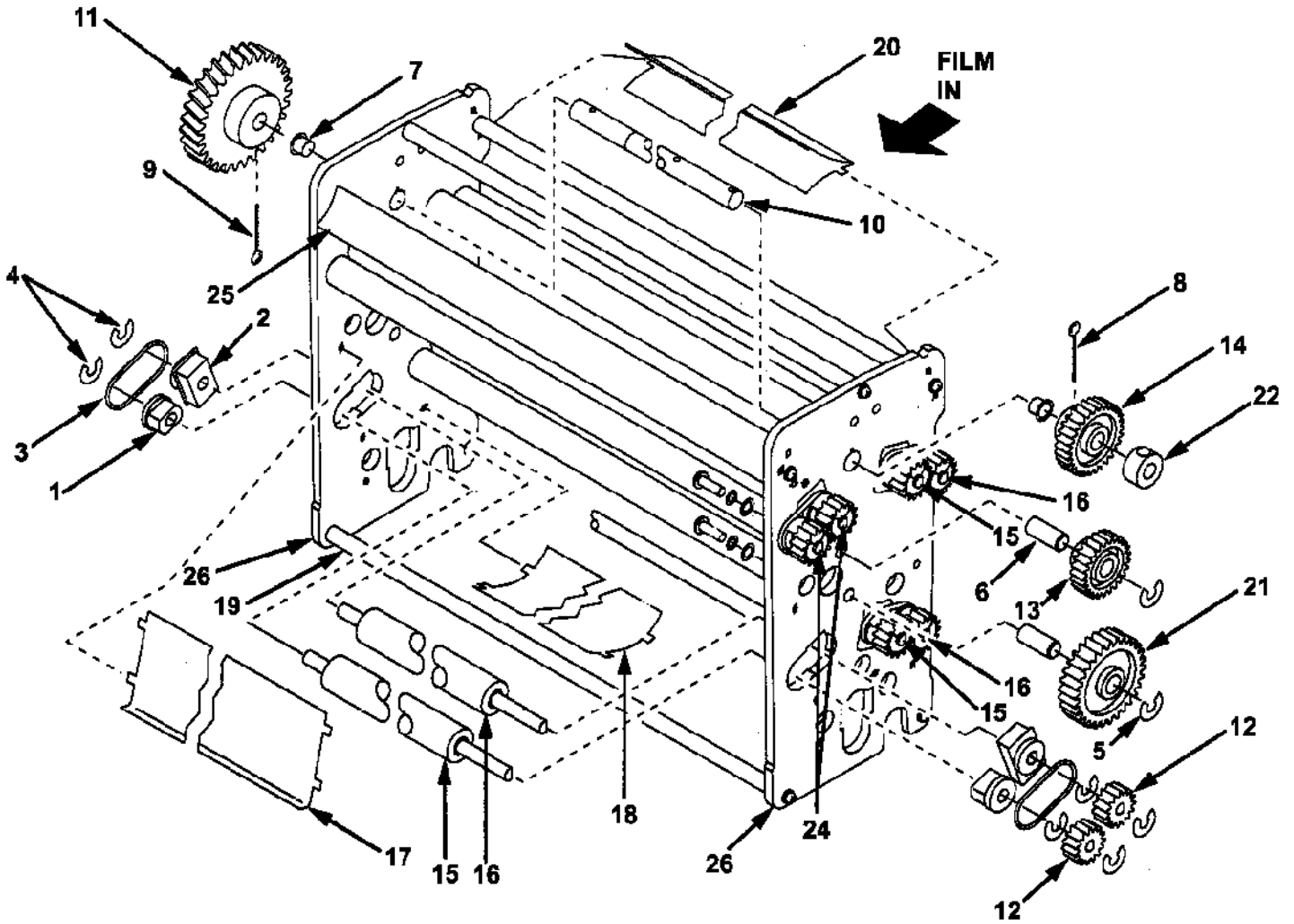

ROLLER IDENTIFICATION

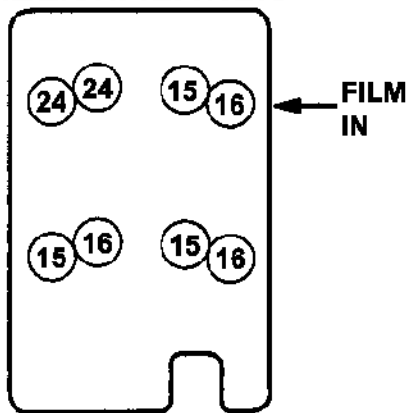

PARTS / ASSEMBLIES

Dryer Transport

ITEM No.	DESCRIPTION	PART No.
1	Bushing, Roller Spring.....	49811
2	Bushing, Roller Spring Square.....	49831
3	O-Ring, Size 120	49823
4	Retainer Clip, Roller Shaft, 1/4"	49807
5	Retainer Clip, Idlers/Drive Shaft, 3/8"	49808
6	Stud, Idler	49822
7	Bearing, 3/8", Nylon	49816
8	Pin, Cotter, 1/16" x 1" Lg.....	30798
9	Pin, Cotter, 1/16" x 1-1/2" Lg	30799
10	Drive Shaft Rod.....	49741
11	Gear, Worm.....	49818
12	Gear, Spur, .75" P.D.	49801
13	Gear, Spur, 1.25" P.D., 3/8" Bore.....	49802
14	Gear, Drive, 1.5" P.D., 3/8" Bore	49803
15	Roller, Rubber, Standard, Black Color.....	49828
16	Roller, Plastic, Golden Color	49872
17	Guide, Flat, Film Transport.....	49815
18	Guide, Arched, Film Transport.....	49824
19	Cross Tie, Dryer Rack	49713
20	Guide, Crossover, Dryer Inlet, Film Transport	47768
23	Gear, Spur, .75" P.D., 3/8" Bore.....	49805
24	Roller, Rubber, Squeegee, Black Color	49835
26	Side Plate, Right.....	47717
27	Side Plate, Left	47718
28	Retainer E-Ring, Drive Shaft	30840
29	Air Port, Right.....	49737
30	Air Port, Left	49738
30a	Gear, Spur, 1.0" P.D., 3/8" Bore.....	47902

NOT ILLUSTRATED

Panel, Front Plate	49727
Panel, Front Baffle	47725

PARTS / ASSEMBLIES

Dryer Transport

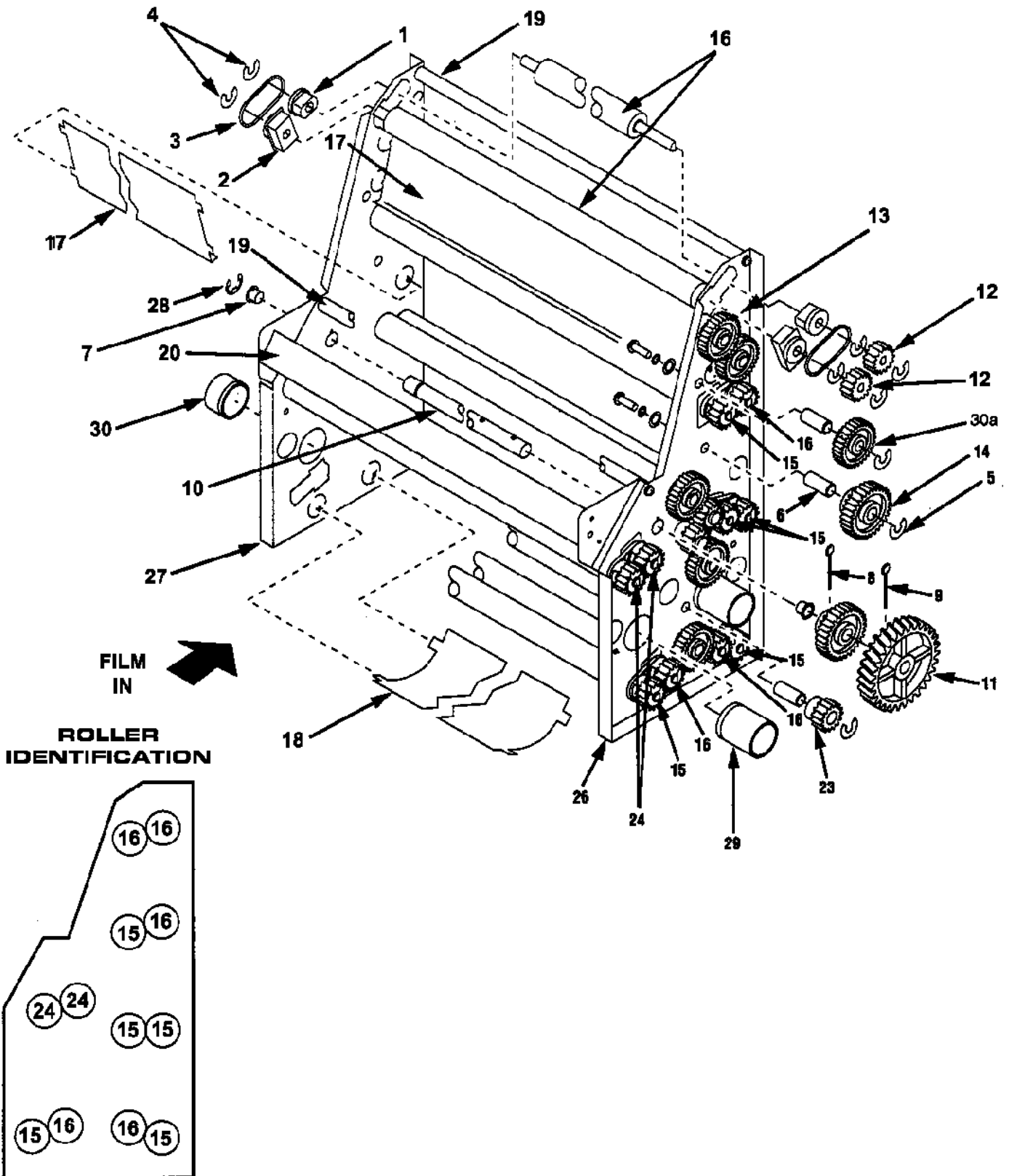

Dryer Transport

ITEM No.	DESCRIPTION	PART No.
31	Reflector, Side	47721
32	Reflector, Top	47722
33	Reflector, Bottom	47774
34	Lamp, Infrared, Front	49751
35	Lamp, Infrared, Middle	49734
36	Lamp, Infrared, Rear	49752
37	Lamp Guard.....	49789
38	Lamp Guard, Snap-on	49616
39	Spring, Lamp Guard Retainer	49791
40	Thermistor Assembly, Dryer	47755
41	Thermostat, Dryer	49736
42	Panel, Dryer Back	47728
43	Harness Assembly, Dryer	47730
44	Grommet, 5/16" I.D.....	49711
45	Bracket, Lamp Holder	49714

PARTS / ASSEMBLIES

Dryer Transport

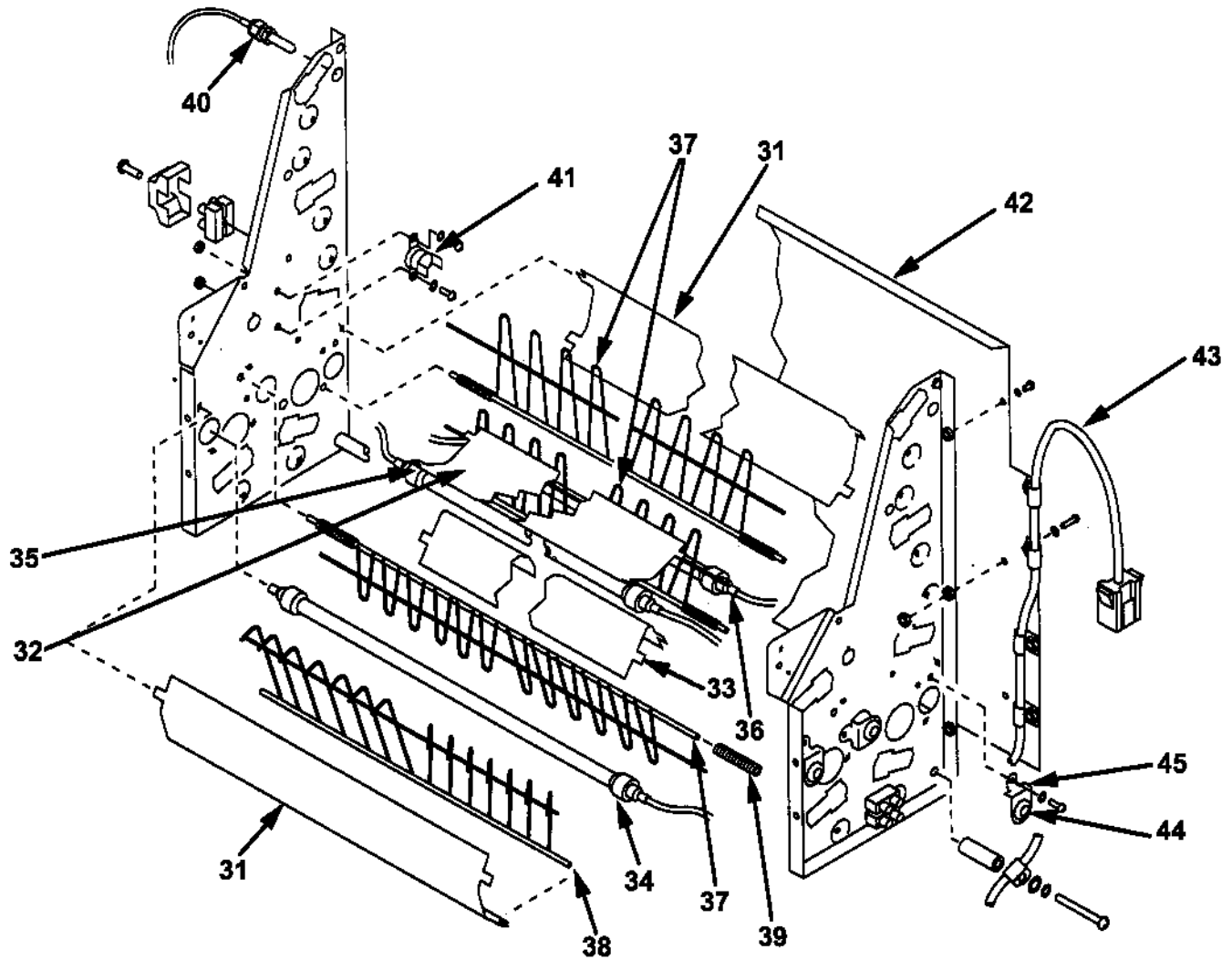

115V WIRING SCHEMATIC

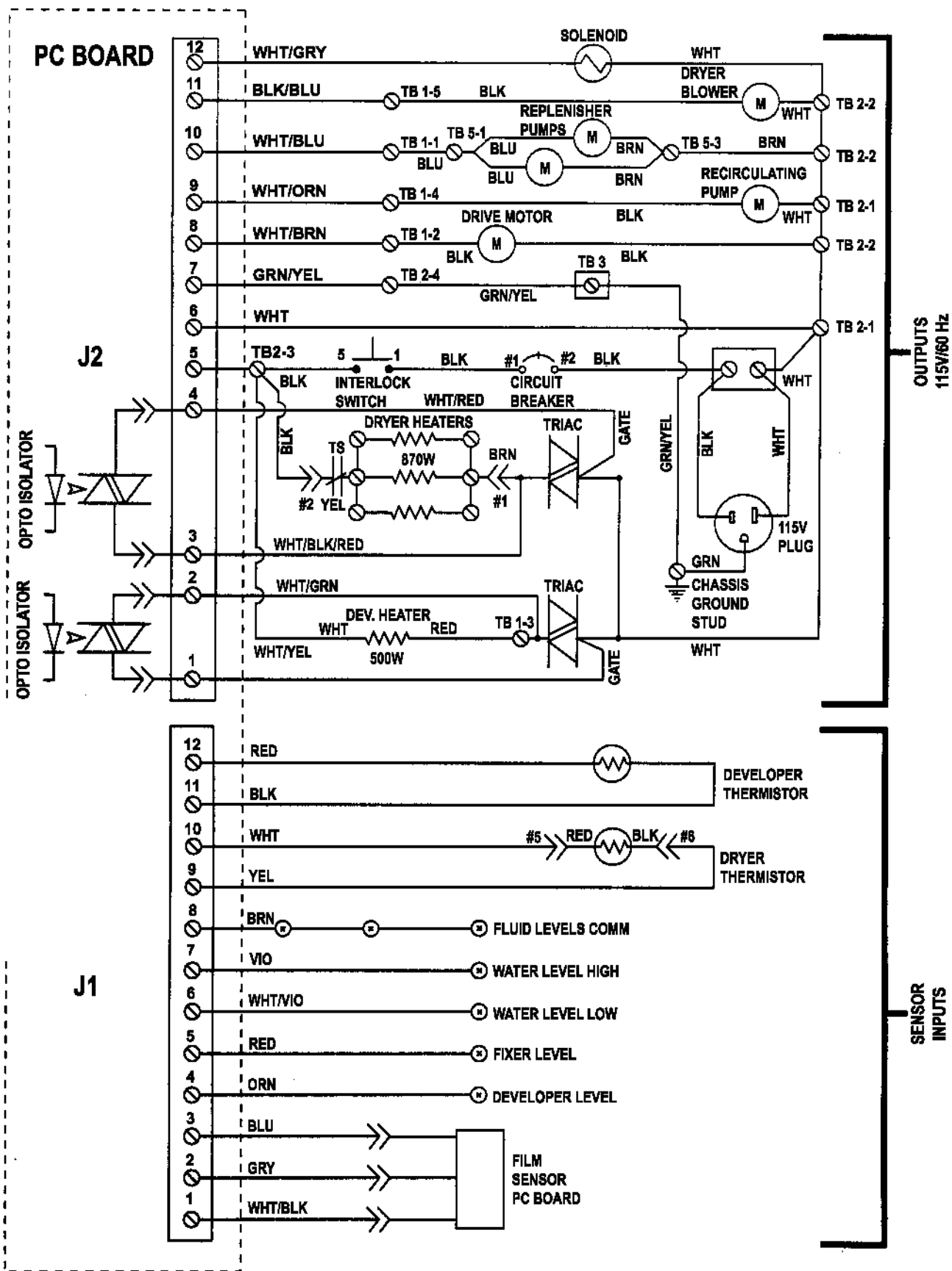

PLUMBING SCHEMATIC

